

ATC Tech Note

Remote Amplifier Mounting

Revision C March 2021

When studio monitors are flush/soffit mounted, the cabinet mounted amplifiers must be removed to ensure they do not overheat and allow access. To help make this as simple as possible remote amp mounting solutions exist for most products and to ensure optimal performance in these situations.

1. SCM20ASL Pro

There is no current off-the-shelf system for remote mounting the amplifier from this product. If you have a special requirement, please contact us to discuss. info@atc.gb.net

2. SCM25/45A Pro & SCM25i/45Ai Pro Remote Amp Mounting

There are four remote amp options for these loudspeaker products:

2.1. RI-234 PRO

This is 5U/19" rack mount version of the 234W, 3-way amp fitted to a single SCM25/45/25i/45i. One is required per speaker. Balanced audio input, AC power and AC switch are located on the front. Speaker level output and LED output are located on the rear via NL8 Speakon and 5-pin XLR respectively. NL8 speaker cables and 5-pin XLR cables (male-male) are required to connect the remote amps and their partnering loudspeakers. Cables are custom built to customers specific requirements and lengths need to be specified when the remote amps are ordered. Full technical product details are available on the technical datasheet.

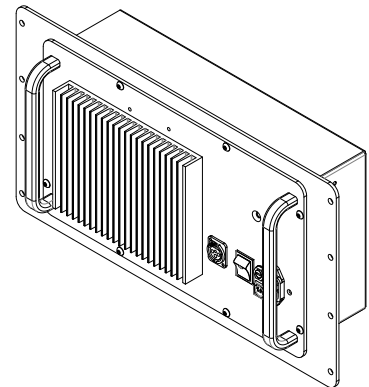

2.2. RI-234 KIT

This is 5U/19" rack mount hardware kit for remote mounting existing SCM25/45 amps in the field. One kit is required per speaker. The kit comprises amp rack mount panel and back-box plus loudspeaker input panel. All connectors and wiring looms are pre-wired so the kit is ready to assemble with existing amps and speakers with minimal fuss. Speaker level output and LED output are located on the rear of the back box via NL8 Speakon and 5-pin XLR respectively. The kit is supplied with pre-assembled input panel for the loudspeakers and identical connectors are used on the speaker input panel. NL8 speaker cables and 5-pin XLR cables (male-male) are required to connect the remote amps and their partnering loudspeakers. Cables are custom built to customers specific requirements and lengths need to be specified when the remote amps are ordered.

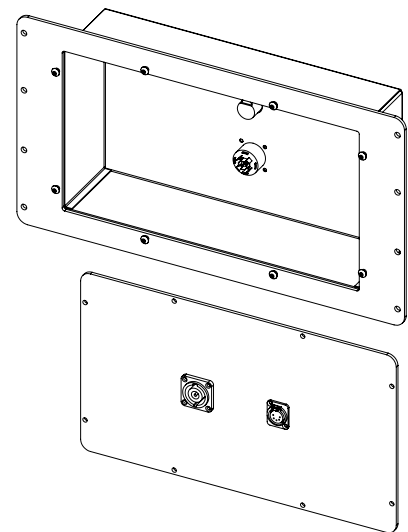

Full technical product details are available on the technical datasheet.

Continued...

2.3. R2-234 PRO

This is a two-channel 5U/19” rack mount version of the 234W, 3-way amp employed in the SCM25A/45A/25Ai/45Ai Pro. A single 2-channel amp partners with a pair of speakers. Balanced input is via three pin XLR. Speaker level output is via Neutrik NL8. Connections to the cabinet mounted off/on/limit LED is via five pin XLR. All connectors are on the rear panel. This product is factory build only. It can’t be used to retro-fit to existing amplifiers in the field. Full technical product details are available on the technical datasheet.

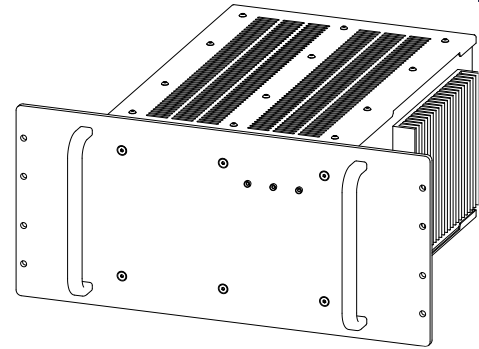

2.4. R3-234 PRO

This is a three-channel 5U/19” rack mount version of the 234W, 3-way amp employed in the SCM25A/45A/25Ai/45Ai Pro. A single 3-channel amp partners three speakers. The chassis dimensions are identical to the two-channel version above and the products are differentiated by their rear panels and weight only. Full technical product details are available on the technical datasheet.

3. SCM50/100/110/150ASL Pro

There are three remote amp options for these loudspeaker products:

3.1. RI-350 PRO

This is 6U/19” rack mount version of the 350W, 3-way amp fitted to a single SCM50/100/110/150ASL Pro. One is required per speaker. Balanced audio input, AC power and AC switch are located on the front. Speaker level output and LED output are located on the rear via NL8 Speakon and 5-pin XLR connectors respectively. NL8 speaker cables and 5-pin XLR cables (male-male) are required to connect the remote amps and their partnering loudspeakers. Cables are custom built to customers specific requirements and lengths need to be specified when the remote amps are ordered.

Full technical product details are available on the technical datasheet.

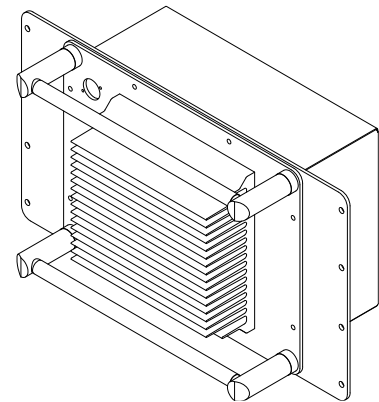

Continued...

3.2. RI-350 KIT

This is 5U/19" rack mount hardware kit for remote mounting existing SCM25/45 amps in the field. One kit is required per speaker. The kit comprises amp rack mount panel and back-box plus loudspeaker input panel. All connectors and wiring looms are pre-wired and fitted so the kit is ready to assemble with existing amps and speakers with minimal fuss.

Speaker level output and LED output are located on the rear via NL8 Speakon and 5-pin XLR respectively. The kit is supplied with pre-assembled input panel for the loudspeakers and identical connectors are used on the speaker input panel. NL8 speaker cables and 5-pin XLR cables (male-male) are required to connect the remote amps and their partnering loudspeakers. Cables are custom built to customers specific requirements and lengths need to be specified when the remote amps are ordered.

Full technical product details are available on the technical datasheet.

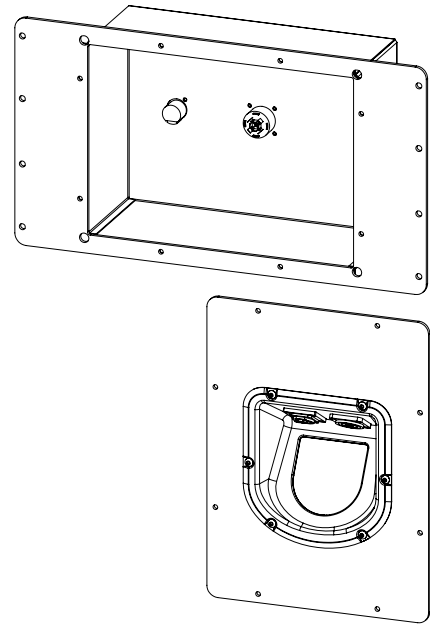

3.3. R2-350 PRO

This is a two-channel 5U/19" rack mount versions of the 350W, 3-way amps employed in the SCM50/100/110/150ASL Pro. A single 2-channel amp partners with a pair of speakers.

Balanced input is via three pin XLR. Speaker level output is via Neutrik NL8. Connections to the cabinet mounted off/on/limit LED is via five pin XLR. All connectors are on the rear panel. This product is factory build only. It can't be used to retro-fit to existing amplifiers in the field.

NL8 speaker cables and 5-pin XLR cables (male-male) are required to connect the remote amps and their partnering loudspeakers. Cables are custom built to customers specific requirements and lengths need to be specified when the remote amps are ordered.

Full technical product details are available on the technical datasheet.

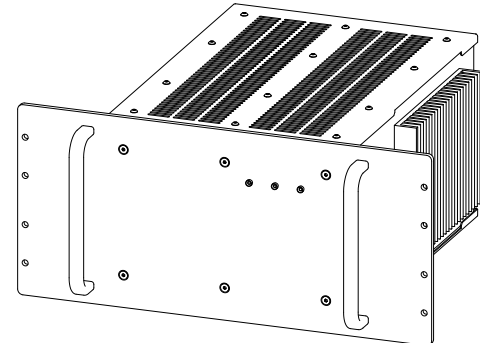

Continued...

4. RI-450 PRO

A single channel 7U 19" rack-mount version of the 450W amplifier fitted to the ATC 12" & 15" Pro subwoofers. One is required per sub (driver). Balanced input is via three pin XLR. Mains power via IEC connector. Both the audio input and mains power are front panel mounted. Speaker level output is via rear mounted Neutrik NL4.

Full technical product details are available on the technical datasheet.

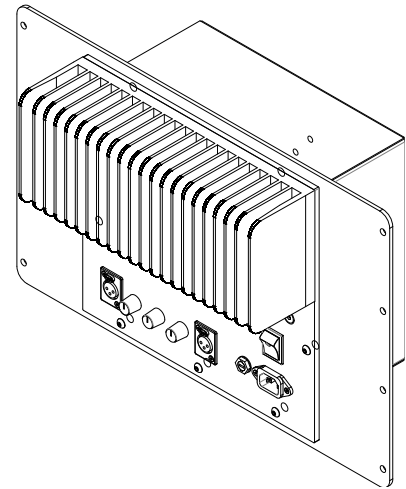

5. Speaker Cabling

One benefit of active loudspeakers with on-board amplifiers is that speaker cables are reduced to the shortest possible length. This ensures minimal loss of audio quality due to losses in speaker cables. With remote amp installs there is the potential for a loss in audio quality due to inferior quality and/or excessive cable lengths. To avoid signal degradation, speaker cables should be kept as short as possible, by mounting the amplifiers close to the loudspeaker locations. **Speaker cable runs over 10m/33' should be avoided if at all possible.**

See 'Table I' at the end of this document detailing dB loss vs cable length.

Continued...

Table 1. dB and Damping Factor Loss Due to Cable Resistance

Cable Length (m)			2		4		6		8		10		12		14		16		18		20	
Cable Gauge	mm ²		2.5	4.0	2.5	4.0	2.5	4.0	2.5	4.0	2.5	4.0	2.5	4.0	2.5	4.0	2.5	4.0	2.5	4.0	2.5	4.0
	AWG		13	11	13	11	13	11	13	11	13	11	13	11	13	11	13	11	13	11	13	11
Cable Loop Resistance (Ω)			0.03	0.02	0.06	0.04	0.09	0.06	0.12	0.07	0.15	0.09	0.18	0.11	0.21	0.13	0.24	0.15	0.28	0.17	0.31	0.18
Amp Damping Factor inc. Cable. Ref. 8Ω			158	208	99	141	72	106	56	85	46	71	39	61	34	54	30	48	27	43	25	39
dB loss driving load of:	6	Ω	-	-	-	-	-	-	-	-	-	-	-	-	-	-	-	-	-	-	-	-
	8	Ω	0.04	0.03	0.09	0.05	0.13	0.08	0.18	0.11	0.22	0.13	0.26	0.16	0.30	0.18	0.35	0.21	0.39	0.24	0.43	0.26
	16	Ω	0.03	0.02	0.07	0.04	0.10	0.06	0.13	0.08	0.16	0.10	0.20	0.12	0.23	0.14	0.26	0.16	0.29	0.18	0.33	0.20
			0.02	0.01	0.03	0.02	0.05	0.03	0.07	0.04	0.08	0.05	0.10	0.06	0.12	0.07	0.13	0.08	0.15	0.09	0.16	0.10

ATC standard cabling uses multi-stranded 2.5mm² or 4.0mm² conductors.

2.5mm² conductor typical resistance is 7.65 ohms per km. Closest equivalent is 13AWG.

4.0mm² conductor typical resistance is 4.6 ohms per km. Closest equivalent is 11AWG.

ATC amplifiers have a damping factor of 400 ref. 8Ω, measured at the O/P terminals.

ATC bass drivers are 8Ω parts. ATC mids are 16Ω parts. ATC HF are 6Ω parts.