

<i>Electroacoustic Specifications</i>	<i>Symbol</i>	<i>Value</i>	<i>Units</i>
Sensitivity	-	dB@1w@1m	dB SPL
Normal Power Rating	-	Watts	Watts
Maximum Input Power	-	Watts	Watts
Maximum Programme Power	-	Watts	Watts
Usable Frequency Range	-	Hz	Hz
Recommended Crossover Frequencies	-	Hz	Hz
Nominal Free Air Resonance	f_s	Hz	Hz
Mechanical Damping	Q_{MS}		-
Electromagnetic Damping	Q_{ES}		-
Total Damping	Q_{TS}		-
Equivalent Compliance Volume	V_{AS}	Litres	Litres
Suspension Compliance	C_{MS}	$x10^{-4}m/N$	$x10^{-4}m \cdot N^{-1}$
Effective Moving Mass	M_{MS}	gms	gms
Mechanical Resistance	R_{MS}	N.s/m	$N \cdot s \cdot m^{-1}$
Voice Coil Diameter	-	mm	mm
Voice Coil Length	-	mm	mm
Voice Coil Nominal Resistance	-	Ohms	Ohms
Voice Coil Nominal Impedance	-	Ohms	Ohms
Voice Coil Maximum Travel Peak to Peak	-	mm	mm
Magnet Total Flux	Φ	$x10^{-3}Wb$	$x10^{-3}Wb$
Magnet Flux Density	B	Tesla	Tesla
Magnet B-I product	B-I	N/A	$N \cdot A^{-1}$
Magnet Gap Length	-	mm	mm
Magnet Gap Volume	-	$x10^{-6}m^3$	$x10^{-6}m^3$
Diaphragm Effective Area	S_D	cm ²	cm ²
<i>Mechanical Specifications</i>			
Surround Type	-		-
Overall Diameter	A	mm	mm
Baffle Hole Diameter	B	mm	mm
Magnet Diameter	C	mm	mm
Front Mount Rebate Depth	D	mm	mm
Overall Depth	E	mm	mm
Mounting Hole Size	F		-
Mounting Hole P.C.D.	G	mm	mm
Shipping Weight	-	kg	kg
Pack Size	-	cm	cm

PA50-314 8 OHM BASS

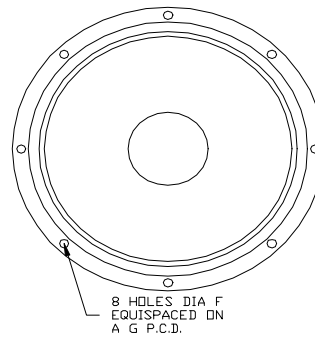
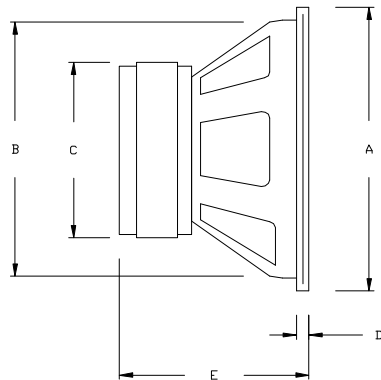
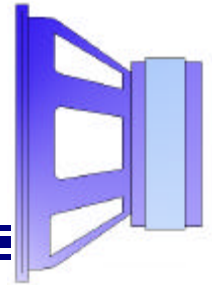

<i>Electroacoustic Specifications</i>	<i>Symbol</i>	<i>Value</i>	<i>Units</i>
Sensitivity	-	100	dB SPL
Normal Power Rating	-	50	Watts
Maximum Input Power	-	100	Watts
Maximum Programme Power	-	200	Watts
Usable Frequency Range	-	Up to 2k	Hz
Recommended Crossover Frequencies	-	200 to 1k6	Hz
Nominal Free Air Resonance	f_s	69	Hz
Mechanical Damping	Q_{MS}	1.86	-
Electromagnetic Damping	Q_{ES}	0.37	-
Total Damping	Q_{TS}	0.31	-
Equivalent Compliance Volume	V_{AS}	47	Litres
Suspension Compliance	C_{MS}	1.5	$\times 10^{-4} \text{m} \cdot \text{N}^{-1}$
Effective Moving Mass	M_{MS}	37	gms
Mechanical Resistance	R_{MS}	9	$\text{N} \cdot \text{s} \cdot \text{m}^{-1}$
Voice Coil Diameter	-	50	mm
Voice Coil Length	-	14	mm
Voice Coil Nominal Resistance	-	5.4	Ohms
Voice Coil Nominal Impedance	-	8	Ohms
Voice Coil Maximum Travel Peak to Peak	-	20	mm
Magnet Total Flux	Φ	2.0	$\times 10^{-3} \text{Wb}$
Magnet Flux Density	B	1.3	Tesla
Magnet B-I product	B-I	15	$\text{N} \cdot \text{A}^{-1}$
Magnet Gap Length	-	9	mm
Magnet Gap Volume	-	1.84	$\times 10^{-6} \text{m}^3$
Diaphragm Effective Area	S_D	550	cm^2
<i>Mechanical Specifications</i>			
Surround Type	-	Fabric	-
Overall Diameter	A	316	mm
Baffle Hole Diameter	B	286	mm
Magnet Diameter	C	156	mm
Front Mount Rebate Depth	D	14	mm
Overall Depth	E	130	mm
Mounting Hole Size	F	8 x M6	-
Mounting Hole P.C.D.	G	300	mm
Shipping Weight	-	7	kg
Pack Size	-	36x36x22	cm

PA50-314 8 OHM BASS R

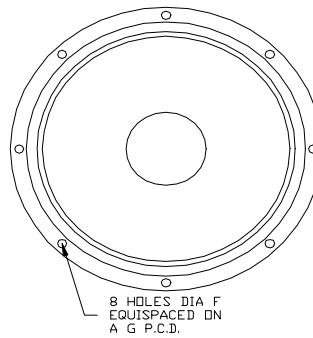
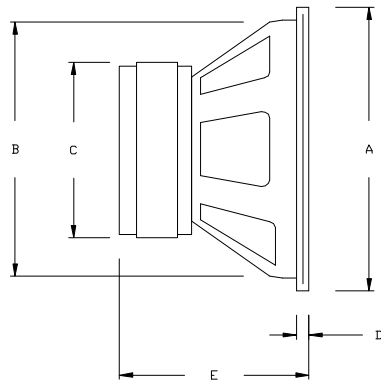
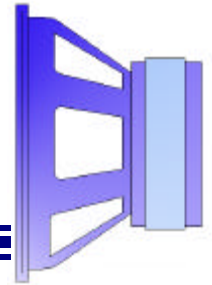

<i>Electroacoustic Specifications</i>	<i>Symbol</i>	<i>Value</i>	<i>Units</i>
Sensitivity	-	97	dB SPL
Normal Power Rating	-	50	Watts
Maximum Input Power	-	100	Watts
Maximum Programme Power	-	200	Watts
Usable Frequency Range	-	Up to 2k	Hz
Recommended Crossover Frequencies	-	200 to 1k6	Hz
Nominal Free Air Resonance	f_s	54	Hz
Mechanical Damping	Q_{MS}	2.06	-
Electromagnetic Damping	Q_{ES}	0.38	-
Total Damping	Q_{TS}	0.32	-
Equivalent Compliance Volume	V_{AS}	67	Litres
Suspension Compliance	C_{MS}	1.9	$\times 10^{-4} \text{m} \cdot \text{N}^{-1}$
Effective Moving Mass	M_{MS}	47	gms
Mechanical Resistance	R_{MS}	8	$\text{N} \cdot \text{s} \cdot \text{m}^{-1}$
Voice Coil Diameter	-	50	mm
Voice Coil Length	-	14	mm
Voice Coil Nominal Resistance	-	5.4	Ohms
Voice Coil Nominal Impedance	-	8	Ohms
Voice Coil Maximum Travel Peak to Peak	-	20	mm
Magnet Total Flux	Φ	2.0	$\times 10^{-3} \text{Wb}$
Magnet Flux Density	B	1.3	Tesla
Magnet B-I product	B-I	16	$\text{N} \cdot \text{A}^{-1}$
Magnet Gap Length	-	9	mm
Magnet Gap Volume	-	1.84	$\times 10^{-6} \text{m}^3$
Diaphragm Effective Area	S_D	550	cm^2
<i>Mechanical Specifications</i>			
Surround Type	-	Rubber	-
Overall Diameter	A	316	mm
Baffle Hole Diameter	B	286	mm
Magnet Diameter	C	156	mm
Front Mount Rebate Depth	D	14	mm
Overall Depth	E	130	mm
Mounting Hole Size	F	8 x M6	-
Mounting Hole P.C.D.	G	300	mm
Shipping Weight	-	7	kg
Pack Size	-	36x36x22	cm

PA50-314 16 OHM BASS

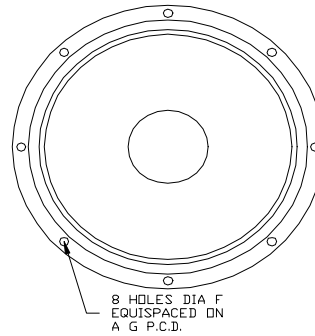
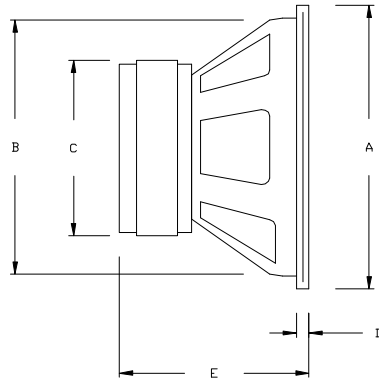
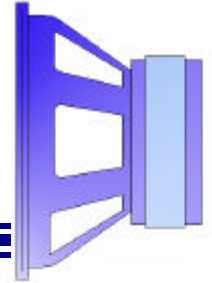

<i>Electroacoustic Specifications</i>	<i>Symbol</i>	<i>Value</i>	<i>Units</i>
Sensitivity	-	95	dB SPL
Normal Power Rating	-	50	Watts
Maximum Input Power	-	100	Watts
Maximum Programme Power	-	200	Watts
Usable Frequency Range	-	Up to 2k	Hz
Recommended Crossover Frequencies	-	250 to 1k6	Hz
Nominal Free Air Resonance	f_s	71	Hz
Mechanical Damping	Q_{MS}	1.89	-
Electromagnetic Damping	Q_{ES}	0.61	-
Total Damping	Q_{TS}	0.46	-
Equivalent Compliance Volume	V_{AS}	45	Litres
Suspension Compliance	C_{MS}	1.4	$\times 10^{-4} \text{m} \cdot \text{N}^{-1}$
Effective Moving Mass	M_{MS}	37	gms
Mechanical Resistance	R_{MS}	9	$\text{N} \cdot \text{s} \cdot \text{m}^{-1}$
Voice Coil Diameter	-	50	mm
Voice Coil Length	-	14	mm
Voice Coil Nominal Resistance	-	11.5	Ohms
Voice Coil Nominal Impedance	-	16	Ohms
Voice Coil Maximum Travel Peak to Peak	-	20	mm
Magnet Total Flux	Φ	2.0	$\times 10^{-3} \text{Wb}$
Magnet Flux Density	B	1.3	Tesla
Magnet B-I product	$B \cdot l$	18	$\text{N} \cdot \text{A}^{-1}$
Magnet Gap Length	-	9	mm
Magnet Gap Volume	-	1.84	$\times 10^{-6} \text{m}^3$
Diaphragm Effective Area	S_D	550	cm^2
<i>Mechanical Specifications</i>			
Surround Type	-	Fabric	-
Overall Diameter	A	316	mm
Baffle Hole Diameter	B	286	mm
Magnet Diameter	C	156	mm
Front Mount Rebate Depth	D	14	mm
Overall Depth	E	130	mm
Mounting Hole Size	F	8 x M6	-
Mounting Hole P.C.D.	G	300	mm
Shipping Weight	-	7	kg
Pack Size	-	36x36x22	cm

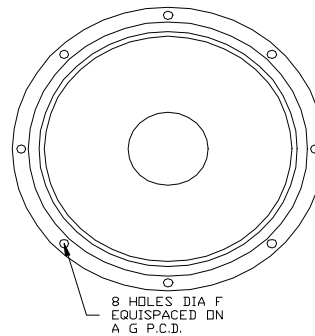
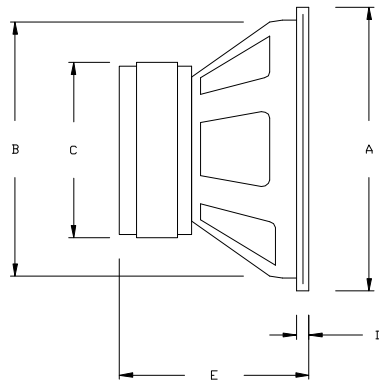
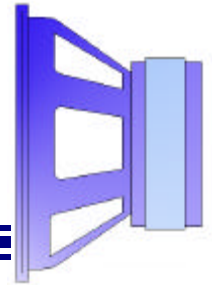

<i>Electroacoustic Specifications</i>	<i>Symbol</i>	<i>Value</i>	<i>Units</i>
Sensitivity	-	99	dB SPL
Normal Power Rating	-	50	Watts
Maximum Input Power	-	100	Watts
Maximum Programme Power	-	200	Watts
Usable Frequency Range	-	Up to 2k	Hz
Recommended Crossover Frequencies	-	200 to 2k	Hz
Nominal Free Air Resonance	f_s	70	Hz
Mechanical Damping	Q_{MS}	1.87	-
Electromagnetic Damping	Q_{ES}	0.43	-
Total Damping	Q_{TS}	0.35	-
Equivalent Compliance Volume	V_{AS}	43	Litres
Suspension Compliance	C_{MS}	1.3	$\times 10^{-4} \text{m} \cdot \text{N}^{-1}$
Effective Moving Mass	M_{MS}	39	gms
Mechanical Resistance	R_{MS}	9	$\text{N} \cdot \text{s} \cdot \text{m}^{-1}$
Voice Coil Diameter	-	50	mm
Voice Coil Length	-	10	mm
Voice Coil Nominal Resistance	-	5.4	Ohms
Voice Coil Nominal Impedance	-	8	Ohms
Voice Coil Maximum Travel Peak to Peak	-	20	mm
Magnet Total Flux	Φ	2.0	$\times 10^{-3} \text{Wb}$
Magnet Flux Density	B	1.3	Tesla
Magnet B-I product	$B \cdot l$	16	$\text{N} \cdot \text{A}^{-1}$
Magnet Gap Length	-	9	mm
Magnet Gap Volume	-	1.84	$\times 10^{-6} \text{m}^3$
Diaphragm Effective Area	S_D	550	cm^2
<i>Mechanical Specifications</i>			
Surround Type	-	Fabric	-
Overall Diameter	A	316	mm
Baffle Hole Diameter	B	286	mm
Magnet Diameter	C	156	mm
Front Mount Rebate Depth	D	14	mm
Overall Depth	E	130	mm
Mounting Hole Size	F	8 x M6	-
Mounting Hole P.C.D.	G	300	mm
Shipping Weight	-	7	kg
Pack Size	-	36x36x22	cm

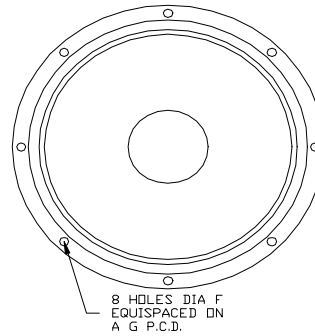
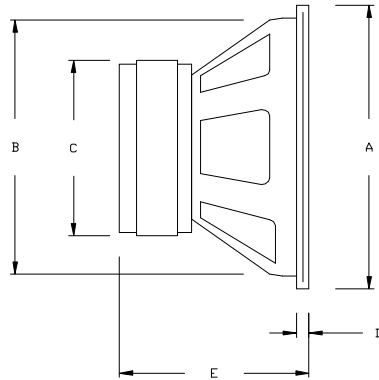
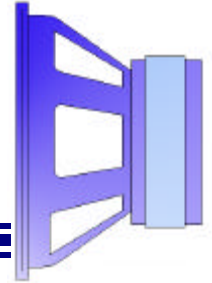

<i>Electroacoustic Specifications</i>	<i>Symbol</i>	<i>Value</i>	<i>Units</i>
Sensitivity	-	96	dB SPL
Normal Power Rating	-	50	Watts
Maximum Input Power	-	100	Watts
Maximum Programme Power	-	200	Watts
Usable Frequency Range	-	Up to 2k	Hz
Recommended Crossover Frequencies	-	200 to 3k	Hz
Nominal Free Air Resonance	f_s	68	Hz
Mechanical Damping	Q_{MS}	1.31	-
Electromagnetic Damping	Q_{ES}	0.44	-
Total Damping	Q_{TS}	0.33	-
Equivalent Compliance Volume	V_{AS}	26	Litres
Suspension Compliance	C_{MS}	1.8	$\times 10^{-4} \text{m} \cdot \text{N}^{-1}$
Effective Moving Mass	M_{MS}	30	gms
Mechanical Resistance	R_{MS}	10	$\text{N} \cdot \text{s} \cdot \text{m}^{-1}$
Voice Coil Diameter	-	50	mm
Voice Coil Length	-	10	mm
Voice Coil Nominal Resistance	-	5.4	Ohms
Voice Coil Nominal Impedance	-	8	Ohms
Voice Coil Maximum Travel Peak to Peak	-	20	mm
Magnet Total Flux	Φ	2.0	$\times 10^{-3} \text{Wb}$
Magnet Flux Density	B	1.3	Tesla
Magnet B-I product	$B \cdot l$	14	$\text{N} \cdot \text{A}^{-1}$
Magnet Gap Length	-	9	mm
Magnet Gap Volume	-	1.84	$\times 10^{-6} \text{m}^3$
Diaphragm Effective Area	S_D	300	cm^2
<i>Mechanical Specifications</i>			
Surround Type	-	Fabric	-
Overall Diameter	A	240	mm
Baffle Hole Diameter	B	212	mm
Magnet Diameter	C	156	mm
Front Mount Rebate Depth	D	13	mm
Overall Depth	E	130	mm
Mounting Hole Size	F	8 x M5	-
Mounting Hole P.C.D.	G	226	mm
Shipping Weight	-	5.5	kg
Pack Size	-	36x36x22	cm

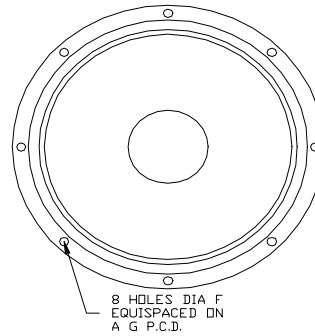
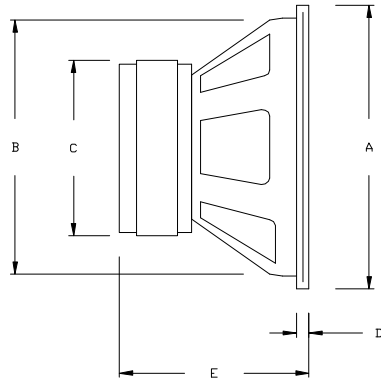
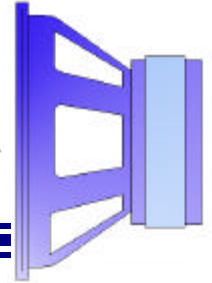

<i>Electroacoustic Specifications</i>	<i>Symbol</i>	<i>Value</i>	<i>Units</i>
Sensitivity	-	94	dB SPL
Normal Power Rating	-	50	Watts
Maximum Input Power	-	100	Watts
Maximum Programme Power	-	200	Watts
Usable Frequency Range	-	Up to 2k	Hz
Recommended Crossover Frequencies	-	250 to 3k	Hz
Nominal Free Air Resonance	f_s	63	Hz
Mechanical Damping	Q_{MS}	1.83	-
Electromagnetic Damping	Q_{ES}	0.33	-
Total Damping	Q_{TS}	0.28	-
Equivalent Compliance Volume	V_{AS}	18	Litres
Suspension Compliance	C_{MS}	1.6	$\times 10^{-4} \text{m} \cdot \text{N}^{-1}$
Effective Moving Mass	M_{MS}	38	gms
Mechanical Resistance	R_{MS}	8	$\text{N} \cdot \text{s} \cdot \text{m}^{-1}$
Voice Coil Diameter	-	50	mm
Voice Coil Length	-	14	mm
Voice Coil Nominal Resistance	-	5.4	Ohms
Voice Coil Nominal Impedance	-	8	Ohms
Voice Coil Maximum Travel Peak to Peak	-	20	mm
Magnet Total Flux	Φ	2.0	$\times 10^{-3} \text{Wb}$
Magnet Flux Density	B	1.3	Tesla
Magnet B-I product	$B \cdot l$	15	$\text{N} \cdot \text{A}^{-1}$
Magnet Gap Length	-	9	mm
Magnet Gap Volume	-	1.84	$\times 10^{-6} \text{m}^3$
Diaphragm Effective Area	S_D	300	cm^2
<i>Mechanical Specifications</i>			
Surround Type	-	Rubber	-
Overall Diameter	A	240	mm
Baffle Hole Diameter	B	212	mm
Magnet Diameter	C	156	mm
Front Mount Rebate Depth	D	13	mm
Overall Depth	E	110	mm
Mounting Hole Size	F	8 x M5	-
Mounting Hole P.C.D.	G	226	mm
Shipping Weight	-	5.5	kg
Pack Size	-	36x36x22	cm

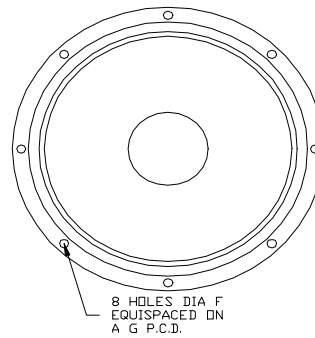
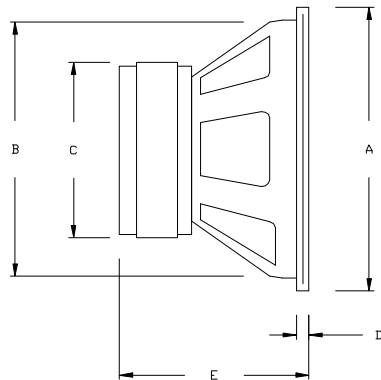
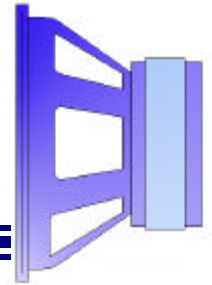

<i>Electroacoustic Specifications</i>	<i>Symbol</i>	<i>Value</i>	<i>Units</i>
Sensitivity	-	98	dB SPL
Normal Power Rating	-	75	Watts
Maximum Input Power	-	150	Watts
Maximum Programme Power	-	300	Watts
Usable Frequency Range	-	Up to 5k	Hz
Recommended Crossover Frequencies	-	250 to 1k6	Hz
Nominal Free Air Resonance	f_s	78	Hz
Mechanical Damping	Q_{MS}	2.63	-
Electromagnetic Damping	Q_{ES}	0.36	-
Total Damping	Q_{TS}	0.32	-
Equivalent Compliance Volume	V_{AS}	17	Litres
Suspension Compliance	C_{MS}	1.4	$\times 10^{-4} \text{m} \cdot \text{N}^{-1}$
Effective Moving Mass	M_{MS}	29	gms
Mechanical Resistance	R_{MS}	5	$\text{N} \cdot \text{s} \cdot \text{m}^{-1}$
Voice Coil Diameter	-	75	mm
Voice Coil Length	-	10	mm
Voice Coil Nominal Resistance	-	5.4	Ohms
Voice Coil Nominal Impedance	-	8	Ohms
Voice Coil Maximum Travel Peak to Peak	-	20	mm
Magnet Total Flux	Φ	2.0	$\times 10^{-3} \text{Wb}$
Magnet Flux Density	B	1.2	Tesla
Magnet B-I product	$B \cdot l$	15	$\text{N} \cdot \text{A}^{-1}$
Magnet Gap Length	-	7.25	mm
Magnet Gap Volume	-	2.14	$\times 10^{-6} \text{m}^3$
Diaphragm Effective Area	S_D	300	cm^2
<i>Mechanical Specifications</i>			
Surround Type	-	Fabric	-
Overall Diameter	A	240	mm
Baffle Hole Diameter	B	212	mm
Magnet Diameter	C	156	mm
Front Mount Rebate Depth	D	13	mm
Overall Depth	E	112	mm
Mounting Hole Size	F	8 x M5	-
Mounting Hole P.C.D.	G	226	mm
Shipping Weight	-	6.36	kg
Pack Size	-	36x36x22	cm

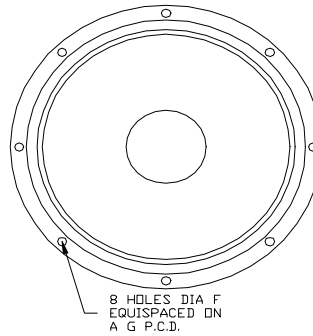
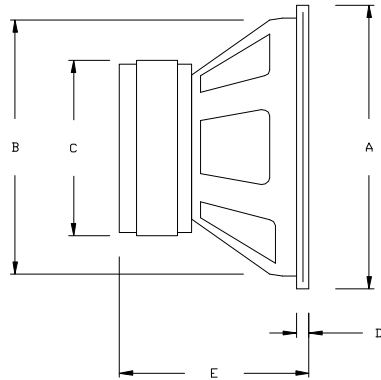

<i>Electroacoustic Specifications</i>	<i>Symbol</i>	<i>Value</i>	<i>Units</i>
Sensitivity	-	95	dB SPL
Normal Power Rating	-	75	Watts
Maximum Input Power	-	150	Watts
Maximum Programme Power	-	300	Watts
Usable Frequency Range	-	Up to 5k	Hz
Recommended Crossover Frequencies	-	Up to 1k6	Hz
Nominal Free Air Resonance	f_s	59	Hz
Mechanical Damping	Q_{MS}	2.27	-
Electromagnetic Damping	Q_{ES}	0.30	-
Total Damping	Q_{TS}	0.26	-
Equivalent Compliance Volume	V_{AS}	22	Litres
Suspension Compliance	C_{MS}	2.0	$\times 10^{-4} \text{m} \cdot \text{N}^{-1}$
Effective Moving Mass	M_{MS}	35	gms
Mechanical Resistance	R_{MS}	6	$\text{N} \cdot \text{s} \cdot \text{m}^{-1}$
Voice Coil Diameter	-	75	mm
Voice Coil Length	-	10	mm
Voice Coil Nominal Resistance	-	5.4	Ohms
Voice Coil Nominal Impedance	-	8	Ohms
Voice Coil Maximum Travel Peak to Peak	-	20	mm
Magnet Total Flux	Φ	2.0	$\times 10^{-3} \text{Wb}$
Magnet Flux Density	B	1.2	Tesla
Magnet B-I product	$B \cdot l$	16	$\text{N} \cdot \text{A}^{-1}$
Magnet Gap Length	-	7.25	mm
Magnet Gap Volume	-	2.14	$\times 10^{-6} \text{m}^3$
Diaphragm Effective Area	S_D	300	cm^2
<i>Mechanical Specifications</i>			
Surround Type	-	Fabric	-
Overall Diameter	A	240	mm
Baffle Hole Diameter	B	212	mm
Magnet Diameter	C	156	mm
Front Mount Rebate Depth	D	13	mm
Overall Depth	E	112	mm
Mounting Hole Size	F	8 x M5	-
Mounting Hole P.C.D.	G	226	mm
Shipping Weight	-	6.36	kg
Pack Size	-	36x36x22	cm

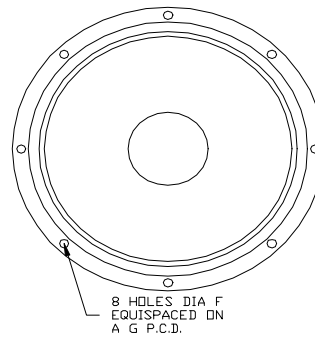
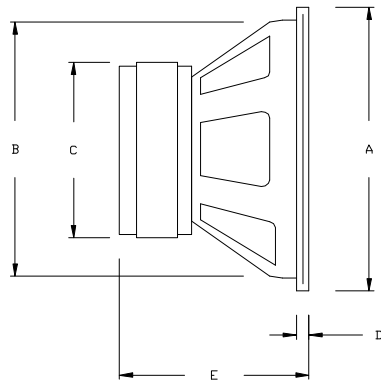
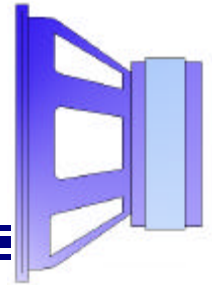

<i>Electroacoustic Specifications</i>	<i>Symbol</i>	<i>Value</i>	<i>Units</i>
Sensitivity	-	93	dB SPL
Normal Power Rating	-	75	Watts
Maximum Input Power	-	150	Watts
Maximum Programme Power	-	300	Watts
Usable Frequency Range	-	Up to 3k5	Hz
Recommended Crossover Frequencies	-	Up to 1k	Hz
Nominal Free Air Resonance	f_s	58	Hz
Mechanical Damping	Q_{MS}	1.48	-
Electromagnetic Damping	Q_{ES}	0.44	-
Total Damping	Q_{TS}	0.34	-
Equivalent Compliance Volume	V_{AS}	22	Litres
Suspension Compliance	C_{MS}	1.9	$\times 10^{-4} \text{m} \cdot \text{N}^{-1}$
Effective Moving Mass	M_{MS}	40	gms
Mechanical Resistance	R_{MS}	10	$\text{N} \cdot \text{s} \cdot \text{m}^{-1}$
Voice Coil Diameter	-	75	mm
Voice Coil Length	-	14	mm
Voice Coil Nominal Resistance	-	5.4	Ohms
Voice Coil Nominal Impedance	-	8	Ohms
Voice Coil Maximum Travel Peak to Peak	-	20	mm
Magnet Total Flux	Φ	2.0	$\times 10^{-3} \text{Wb}$
Magnet Flux Density	B	1.1	Tesla
Magnet B-I product	B-I	12	$\text{N} \cdot \text{A}^{-1}$
Magnet Gap Length	-	7.25	mm
Magnet Gap Volume	-	2.68	$\times 10^{-6} \text{m}^3$
Diaphragm Effective Area	S_D	300	cm^2
<i>Mechanical Specifications</i>			
Surround Type	-	Fabric	-
Overall Diameter	A	240	mm
Baffle Hole Diameter	B	212	mm
Magnet Diameter	C	156	mm
Front Mount Rebate Depth	D	13	mm
Overall Depth	E	112	mm
Mounting Hole Size	F	8 x M5	-
Mounting Hole P.C.D.	G	226	mm
Shipping Weight	-	6.36	kg
Pack Size	-	36x36x22	cm

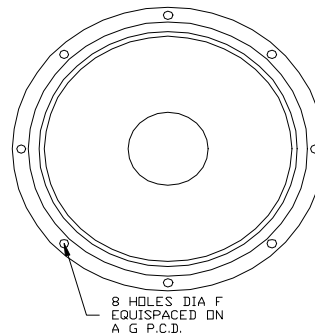
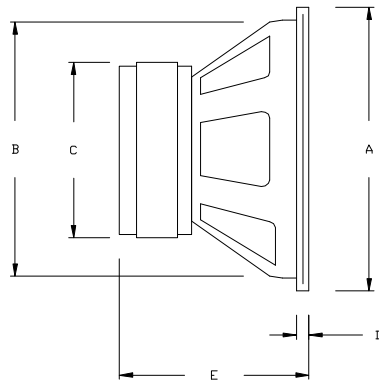
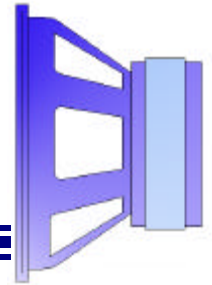

<i>Electroacoustic Specifications</i>	<i>Symbol</i>	<i>Value</i>	<i>Units</i>
Sensitivity	-	95	dB SPL
Normal Power Rating	-	75	Watts
Maximum Input Power	-	150	Watts
Maximum Programme Power	-	300	Watts
Usable Frequency Range	-	Up to 3k	Hz
Recommended Crossover Frequencies	-	Up to 1k	Hz
Nominal Free Air Resonance	f_s	49	Hz
Mechanical Damping	Q_{MS}	1.46	-
Electromagnetic Damping	Q_{ES}	0.33	-
Total Damping	Q_{TS}	0.27	-
Equivalent Compliance Volume	V_{AS}	33	Litres
Suspension Compliance	C_{MS}	2.9	$\times 10^{-4} \text{m} \cdot \text{N}^{-1}$
Effective Moving Mass	M_{MS}	36	gms
Mechanical Resistance	R_{MS}	8	$\text{N} \cdot \text{s} \cdot \text{m}^{-1}$
Voice Coil Diameter	-	75	mm
Voice Coil Length	-	16	mm
Voice Coil Nominal Resistance	-	5.4	Ohms
Voice Coil Nominal Impedance	-	8	Ohms
Voice Coil Maximum Travel Peak to Peak	-	20	mm
Magnet Total Flux	Φ	2.0	$\times 10^{-3} \text{Wb}$
Magnet Flux Density	B	1.1	Tesla
Magnet B-I product	$B \cdot l$	14	$\text{N} \cdot \text{A}^{-1}$
Magnet Gap Length	-	7.25	mm
Magnet Gap Volume	-	2.68	$\times 10^{-6} \text{m}^3$
Diaphragm Effective Area	S_D	300	cm^2
<i>Mechanical Specifications</i>			
Surround Type	-	Fabric	-
Overall Diameter	A	240	mm
Baffle Hole Diameter	B	212	mm
Magnet Diameter	C	156	mm
Front Mount Rebate Depth	D	13	mm
Overall Depth	E	112	mm
Mounting Hole Size	F	8 x M5	-
Mounting Hole P.C.D.	G	226	mm
Shipping Weight	-	6.36	kg
Pack Size	-	36x36x22	cm

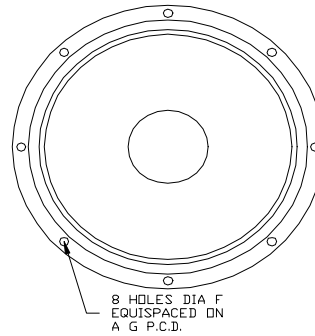
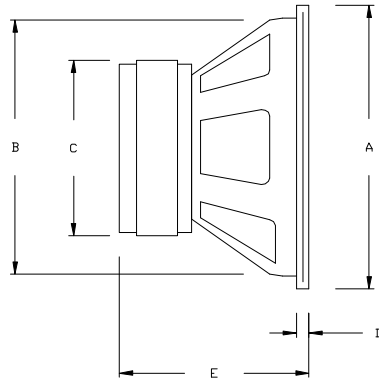
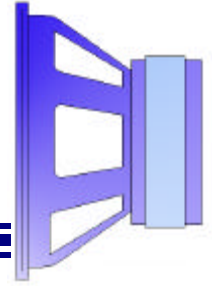

<i>Electroacoustic Specifications</i>	<i>Symbol</i>	<i>Value</i>	<i>Units</i>
Sensitivity	-	92	dB SPL
Normal Power Rating	-	75	Watts
Maximum Input Power	-	150	Watts
Maximum Programme Power	-	300	Watts
Usable Frequency Range	-	Up to 3k	Hz
Recommended Crossover Frequencies	-	Up to 1k	Hz
Nominal Free Air Resonance	f_s	27	Hz
Mechanical Damping	Q_{MS}	1.19	-
Electromagnetic Damping	Q_{ES}	0.21	-
Total Damping	Q_{TS}	0.18	-
Equivalent Compliance Volume	V_{AS}	79	Litres
Suspension Compliance	C_{MS}	6.6	$\times 10^{-4} \text{m} \cdot \text{N}^{-1}$
Effective Moving Mass	M_{MS}	51	gms
Mechanical Resistance	R_{MS}	7	$\text{N} \cdot \text{s} \cdot \text{m}^{-1}$
Voice Coil Diameter	-	75	mm
Voice Coil Length	-	16	mm
Voice Coil Nominal Resistance	-	5.4	Ohms
Voice Coil Nominal Impedance	-	8	Ohms
Voice Coil Maximum Travel Peak to Peak	-	20	mm
Magnet Total Flux	Φ	2.0	$\times 10^{-3} \text{Wb}$
Magnet Flux Density	B	1.1	Tesla
Magnet B-I product	B-I	14	$\text{N} \cdot \text{A}^{-1}$
Magnet Gap Length	-	7.25	mm
Magnet Gap Volume	-	2.68	$\times 10^{-6} \text{m}^3$
Diaphragm Effective Area	S_D	300	cm^2
<i>Mechanical Specifications</i>			
Surround Type	-	Rubber	-
Overall Diameter	A	240	mm
Baffle Hole Diameter	B	212	mm
Magnet Diameter	C	156	mm
Front Mount Rebate Depth	D	13	mm
Overall Depth	E	112	mm
Mounting Hole Size	F	8 x M5	-
Mounting Hole P.C.D.	G	226	mm
Shipping Weight	-	6.36	kg
Pack Size	-	36x36x22	cm

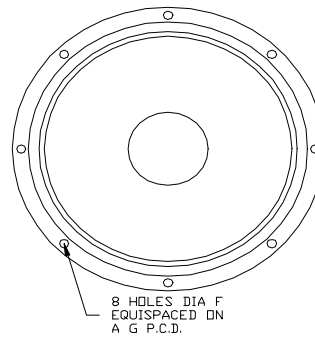
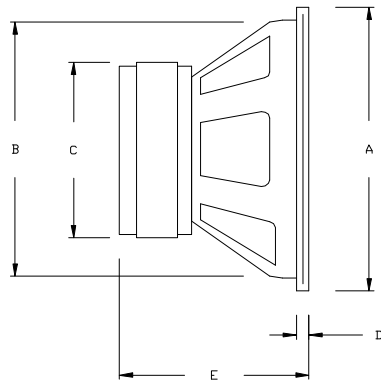
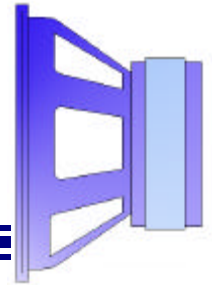

<i>Electroacoustic Specifications</i>	<i>Symbol</i>	<i>Value</i>	<i>Units</i>
Sensitivity	-	85	dB SPL
Normal Power Rating	-	75	Watts
Maximum Input Power	-	150	Watts
Maximum Programme Power	-	300	Watts
Usable Frequency Range	-	Up to 3k	Hz
Recommended Crossover Frequencies	-	Up to 1k	Hz
Nominal Free Air Resonance	f_s	31	Hz
Mechanical Damping	Q_{MS}	1.70	-
Electromagnetic Damping	Q_{ES}	0.40	-
Total Damping	Q_{TS}	0.33	-
Equivalent Compliance Volume	V_{AS}	76	Litres
Suspension Compliance	C_{MS}	6.5	$\times 10^{-4} \text{m} \cdot \text{N}^{-1}$
Effective Moving Mass	M_{MS}	41	gms
Mechanical Resistance	R_{MS}	5	$\text{N} \cdot \text{s} \cdot \text{m}^{-1}$
Voice Coil Diameter	-	75	mm
Voice Coil Length	-	10	mm
Voice Coil Nominal Resistance	-	6.6	Ohms
Voice Coil Nominal Impedance	-	8	Ohms
Voice Coil Maximum Travel Peak to Peak	-	20	mm
Magnet Total Flux	Φ	3.1	$\times 10^{-3} \text{Wb}$
Magnet Flux Density	B	0.9	Tesla
Magnet B-I product	$B \cdot l$	11	$\text{N} \cdot \text{A}^{-1}$
Magnet Gap Length	-	18	mm
Magnet Gap Volume	-	5.20	$\times 10^{-6} \text{m}^3$
Diaphragm Effective Area	S_D	300	cm^2
<i>Mechanical Specifications</i>			
Surround Type	-	Rubber	-
Overall Diameter	A	240	mm
Baffle Hole Diameter	B	212	mm
Magnet Diameter	C	156	mm
Front Mount Rebate Depth	D	13	mm
Overall Depth	E	125	mm
Mounting Hole Size	F	8 x M5	-
Mounting Hole P.C.D.	G	226	mm
Shipping Weight	-	8.18	kg
Pack Size	-	36x36x22	cm

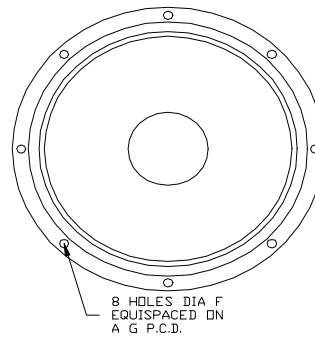
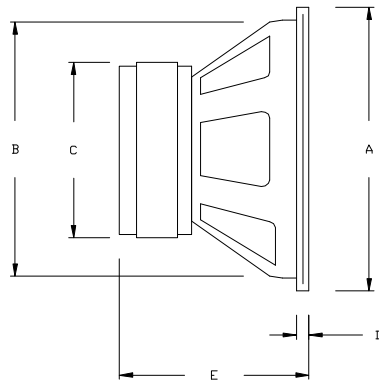
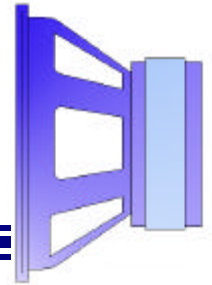

<i>Electroacoustic Specifications</i>	<i>Symbol</i>	<i>Value</i>	<i>Units</i>
Sensitivity	-	87	dB SPL
Normal Power Rating	-	75	Watts
Maximum Input Power	-	150	Watts
Maximum Programme Power	-	300	Watts
Usable Frequency Range	-	Up to 3k	Hz
Recommended Crossover Frequencies	-	Up to 1k	Hz
Nominal Free Air Resonance	f_s	26	Hz
Mechanical Damping	Q_{MS}	1.06	-
Electromagnetic Damping	Q_{ES}	0.21	-
Total Damping	Q_{TS}	0.18	-
Equivalent Compliance Volume	V_{AS}	70	Litres
Suspension Compliance	C_{MS}	6.2	$\times 10^{-4} \text{m} \cdot \text{N}^{-1}$
Effective Moving Mass	M_{MS}	59	gms
Mechanical Resistance	R_{MS}	9	$\text{N} \cdot \text{s} \cdot \text{m}^{-1}$
Voice Coil Diameter	-	75	mm
Voice Coil Length	-	16	mm
Voice Coil Nominal Resistance	-	5.4	Ohms
Voice Coil Nominal Impedance	-	8	Ohms
Voice Coil Maximum Travel Peak to Peak	-	20	mm
Magnet Total Flux	Φ	1.9	$\times 10^{-3} \text{Wb}$
Magnet Flux Density	B	1.1	Tesla
Magnet B-I product	$B \cdot l$	14	$\text{N} \cdot \text{A}^{-1}$
Magnet Gap Length	-	7.25	mm
Magnet Gap Volume	-	2.68	$\times 10^{-6} \text{m}^3$
Diaphragm Effective Area	S_D	300	cm^2
<i>Mechanical Specifications</i>			
Surround Type	-	Rubber	-
Overall Diameter	A	240	mm
Baffle Hole Diameter	B	212	mm
Magnet Diameter	C	156	mm
Front Mount Rebate Depth	D	13	mm
Overall Depth	E	112	mm
Mounting Hole Size	F	8 x M5	-
Mounting Hole P.C.D.	G	226	mm
Shipping Weight	-	6.36	kg
Pack Size	-	36x36x22	cm

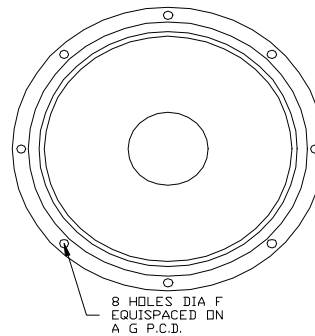
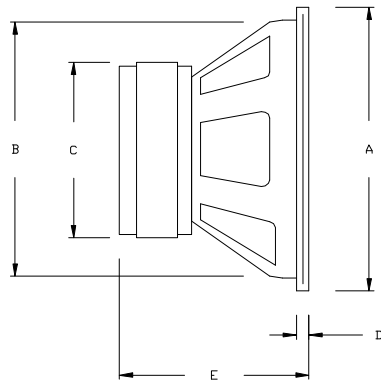
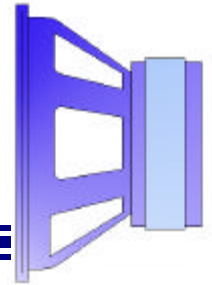

<i>Electroacoustic Specifications</i>	<i>Symbol</i>	<i>Value</i>	<i>Units</i>
Sensitivity	-	-	dB SPL
Normal Power Rating	-	-	Watts
Maximum Input Power	-	-	Watts
Maximum Programme Power	-	-	Watts
Usable Frequency Range	-	-	Hz
Recommended Crossover Frequencies	-	-	Hz
Nominal Free Air Resonance	f_s	-	Hz
Mechanical Damping	Q_{MS}	-	-
Electromagnetic Damping	Q_{ES}	-	-
Total Damping	Q_{TS}	-	-
Equivalent Compliance Volume	V_{AS}	-	Litres
Suspension Compliance	C_{MS}	-	$\times 10^{-4} \text{m} \cdot \text{N}^{-1}$
Effective Moving Mass	M_{MS}	-	gms
Mechanical Resistance	R_{MS}	-	$\text{N} \cdot \text{s} \cdot \text{m}^{-1}$
Voice Coil Diameter	-	-	mm
Voice Coil Length	-	-	mm
Voice Coil Nominal Resistance	-	-	Ohms
Voice Coil Nominal Impedance	-	-	Ohms
Voice Coil Maximum Travel Peak to Peak	-	-	mm
Magnet Total Flux	Φ	-	$\times 10^{-3} \text{Wb}$
Magnet Flux Density	B	-	Tesla
Magnet B-I product	$B \cdot l$	-	$\text{N} \cdot \text{A}^{-1}$
Magnet Gap Length	-	-	mm
Magnet Gap Volume	-	-	$\times 10^{-6} \text{m}^3$
Diaphragm Effective Area	S_D	-	cm^2
<i>Mechanical Specifications</i>			
Surround Type	-	-	-
Overall Diameter	A	-	mm
Baffle Hole Diameter	B	-	mm
Magnet Diameter	C	-	mm
Front Mount Rebate Depth	D	-	mm
Overall Depth	E	-	mm
Mounting Hole Size	F	-	-
Mounting Hole P.C.D.	G	-	mm
Shipping Weight	-	-	kg
Pack Size	-	-	cm

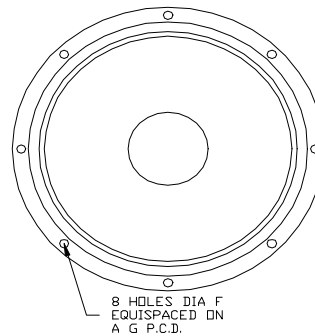
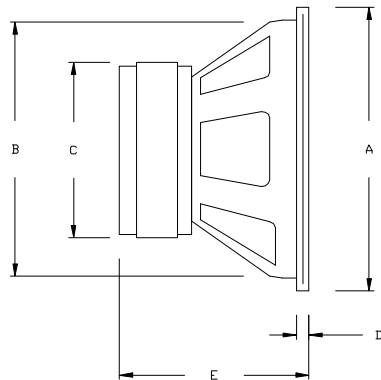
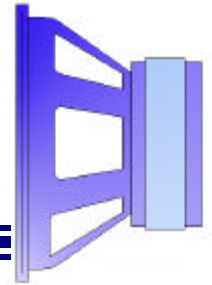

<i>Electroacoustic Specifications</i>	<i>Symbol</i>	<i>Value</i>	<i>Units</i>
Sensitivity	-	99	dB SPL
Normal Power Rating	-	75	Watts
Maximum Input Power	-	150	Watts
Maximum Programme Power	-	300	Watts
Usable Frequency Range	-	Up to 6k	Hz
Recommended Crossover Frequencies	-	250 to 1k6	Hz
Nominal Free Air Resonance	f_s	57	Hz
Mechanical Damping	Q_{MS}	2.41	-
Electromagnetic Damping	Q_{ES}	0.39	-
Total Damping	Q_{TS}	0.34	-
Equivalent Compliance Volume	V_{AS}	51	Litres
Suspension Compliance	C_{MS}	1.5	$\times 10^{-4} \text{m} \cdot \text{N}^{-1}$
Effective Moving Mass	M_{MS}	51	gms
Mechanical Resistance	R_{MS}	8	$\text{N} \cdot \text{s} \cdot \text{m}^{-1}$
Voice Coil Diameter	-	75	mm
Voice Coil Length	-	10	mm
Voice Coil Nominal Resistance	-	5.4	Ohms
Voice Coil Nominal Impedance	-	8	Ohms
Voice Coil Maximum Travel Peak to Peak	-	20	mm
Magnet Total Flux	Φ	3.1	$\times 10^{-3} \text{Wb}$
Magnet Flux Density	B	1.3	Tesla
Magnet B-I product	$B \cdot l$	15	$\text{N} \cdot \text{A}^{-1}$
Magnet Gap Length	-	10	mm
Magnet Gap Volume	-	2.92	$\times 10^{-6} \text{m}^3$
Diaphragm Effective Area	S_D	550	cm^2
<i>Mechanical Specifications</i>			
Surround Type	-	Fabric	-
Overall Diameter	A	316	mm
Baffle Hole Diameter	B	286	mm
Magnet Diameter	C	181	mm
Front Mount Rebate Depth	D	14	mm
Overall Depth	E	140	mm
Mounting Hole Size	F	8 x M6	-
Mounting Hole P.C.D.	G	300	mm
Shipping Weight	-	8.6	kg
Pack Size	-	36x36x22	cm

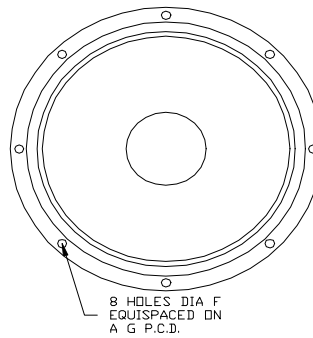
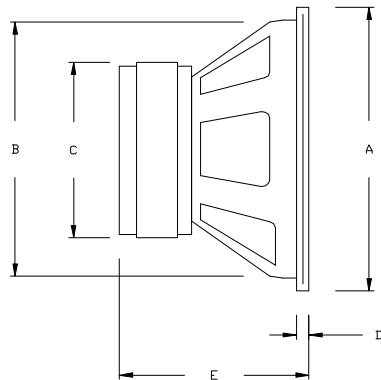

<i>Electroacoustic Specifications</i>	<i>Symbol</i>	<i>Value</i>	<i>Units</i>
Sensitivity	-	98	dB SPL
Normal Power Rating	-	75	Watts
Maximum Input Power	-	150	Watts
Maximum Programme Power	-	300	Watts
Usable Frequency Range	-	Up to 6k	Hz
Recommended Crossover Frequencies	-	Up to 1k6	Hz
Nominal Free Air Resonance	f_s	71	Hz
Mechanical Damping	Q_{MS}	2.47	-
Electromagnetic Damping	Q_{ES}	0.39	-
Total Damping	Q_{TS}	0.34	-
Equivalent Compliance Volume	V_{AS}	35	Litres
Suspension Compliance	C_{MS}	1.1	$\times 10^{-4} \text{m} \cdot \text{N}^{-1}$
Effective Moving Mass	M_{MS}	46	gms
Mechanical Resistance	R_{MS}	8	$\text{N} \cdot \text{s} \cdot \text{m}^{-1}$
Voice Coil Diameter	-	75	mm
Voice Coil Length	-	10	mm
Voice Coil Nominal Resistance	-	5.4	Ohms
Voice Coil Nominal Impedance	-	8	Ohms
Voice Coil Maximum Travel Peak to Peak	-	20	mm
Magnet Total Flux	Φ	3.1	$\times 10^{-3} \text{Wb}$
Magnet Flux Density	B	1.3	Tesla
Magnet B-I product	B-I	16	$\text{N} \cdot \text{A}^{-1}$
Magnet Gap Length	-	10	mm
Magnet Gap Volume	-	2.92	$\times 10^{-6} \text{m}^3$
Diaphragm Effective Area	S_D	550	cm^2
<i>Mechanical Specifications</i>			
Surround Type	-	Fabric	-
Overall Diameter	A	316	mm
Baffle Hole Diameter	B	286	mm
Magnet Diameter	C	181	mm
Front Mount Rebate Depth	D	14	mm
Overall Depth	E	140	mm
Mounting Hole Size	F	8 x M6	-
Mounting Hole P.C.D.	G	300	mm
Shipping Weight	-	8.6	kg
Pack Size	-	36x36x22	cm

PA75-314 BASS

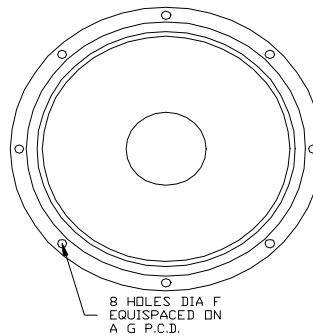
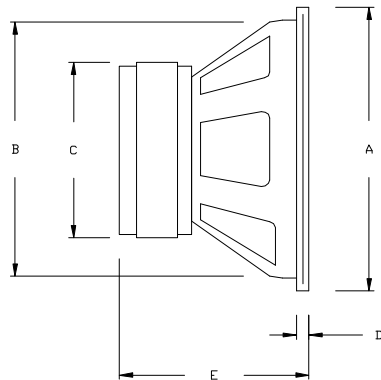
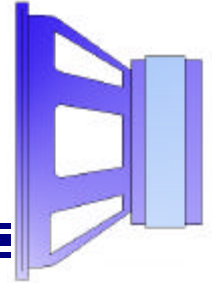

<i>Electroacoustic Specifications</i>	<i>Symbol</i>	<i>Value</i>	<i>Units</i>
Sensitivity	-	98	dB SPL
Normal Power Rating	-	75	Watts
Maximum Input Power	-	150	Watts
Maximum Programme Power	-	300	Watts
Usable Frequency Range	-	Up to 5k	Hz
Recommended Crossover Frequencies	-	Up to 1k6	Hz
Nominal Free Air Resonance	f_s	59	Hz
Mechanical Damping	Q_{MS}	1.48	-
Electromagnetic Damping	Q_{ES}	0.36	-
Total Damping	Q_{TS}	0.29	-
Equivalent Compliance Volume	V_{AS}	50	Litres
Suspension Compliance	C_{MS}	1.4	$\times 10^{-4} \text{m} \cdot \text{N}^{-1}$
Effective Moving Mass	M_{MS}	50	gms
Mechanical Resistance	R_{MS}	13	$\text{N} \cdot \text{s} \cdot \text{m}^{-1}$
Voice Coil Diameter	-	75	mm
Voice Coil Length	-	14	mm
Voice Coil Nominal Resistance	-	5.4	Ohms
Voice Coil Nominal Impedance	-	8	Ohms
Voice Coil Maximum Travel Peak to Peak	-	20	mm
Magnet Total Flux	Φ	2.7	$\times 10^{-3} \text{Wb}$
Magnet Flux Density	B	1.2	Tesla
Magnet B-I product	$B \cdot l$	17	$\text{N} \cdot \text{A}^{-1}$
Magnet Gap Length	-	10	mm
Magnet Gap Volume	-	3.67	$\times 10^{-6} \text{m}^3$
Diaphragm Effective Area	S_D	550	cm^2
<i>Mechanical Specifications</i>			
Surround Type	-	Fabric	-
Overall Diameter	A	316	mm
Baffle Hole Diameter	B	286	mm
Magnet Diameter	C	181	mm
Front Mount Rebate Depth	D	14	mm
Overall Depth	E	140	mm
Mounting Hole Size	F	8 x M6	-
Mounting Hole P.C.D.	G	300	mm
Shipping Weight	-	8.6	kg
Pack Size	-	36x36x22	cm

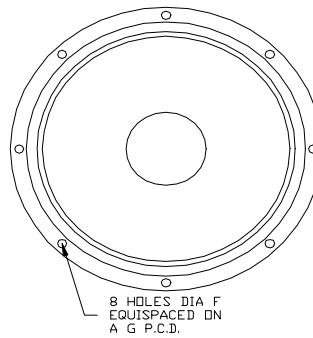
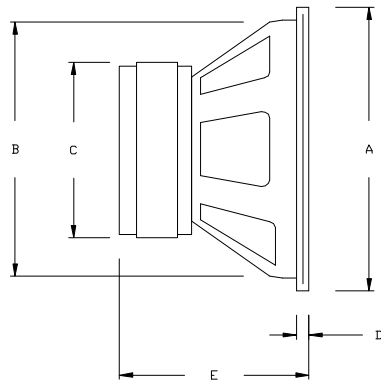
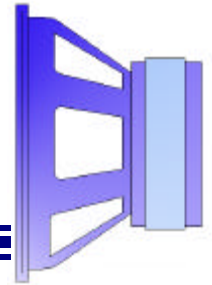

<i>Electroacoustic Specifications</i>	<i>Symbol</i>	<i>Value</i>	<i>Units</i>
Sensitivity	-	95	dB SPL
Normal Power Rating	-	75	Watts
Maximum Input Power	-	150	Watts
Maximum Programme Power	-	300	Watts
Usable Frequency Range	-	Up to 3k5	Hz
Recommended Crossover Frequencies	-	Up to 1k	Hz
Nominal Free Air Resonance	f_s	59	Hz
Mechanical Damping	Q_{MS}	1.25	-
Electromagnetic Damping	Q_{ES}	0.29	-
Total Damping	Q_{TS}	0.23	-
Equivalent Compliance Volume	V_{AS}	49	Litres
Suspension Compliance	C_{MS}	1.4	$\times 10^{-4} \text{m} \cdot \text{N}^{-1}$
Effective Moving Mass	M_{MS}	53	gms
Mechanical Resistance	R_{MS}	16	$\text{N} \cdot \text{s} \cdot \text{m}^{-1}$
Voice Coil Diameter	-	75	mm
Voice Coil Length	-	16	mm
Voice Coil Nominal Resistance	-	5.4	Ohms
Voice Coil Nominal Impedance	-	8	Ohms
Voice Coil Maximum Travel Peak to Peak	-	20	mm
Magnet Total Flux	Φ	2.7	$\times 10^{-3} \text{Wb}$
Magnet Flux Density	B	1.2	Tesla
Magnet B-I product	$B \cdot l$	19	$\text{N} \cdot \text{A}^{-1}$
Magnet Gap Length	-	10	mm
Magnet Gap Volume	-	3.67	$\times 10^{-6} \text{m}^3$
Diaphragm Effective Area	S_D	550	cm^2
<i>Mechanical Specifications</i>			
Surround Type	-	Fabric	-
Overall Diameter	A	316	mm
Baffle Hole Diameter	B	286	mm
Magnet Diameter	C	181	mm
Front Mount Rebate Depth	D	14	mm
Overall Depth	E	140	mm
Mounting Hole Size	F	8 x M6	-
Mounting Hole P.C.D.	G	300	mm
Shipping Weight	-	8.6	kg
Pack Size	-	36x36x22	cm

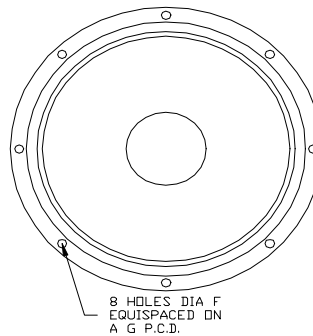
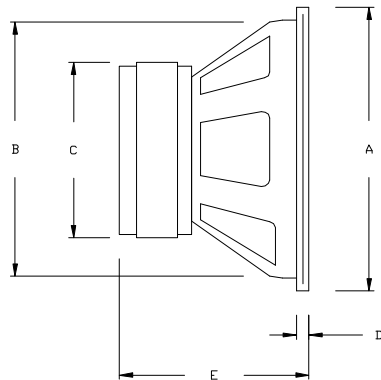
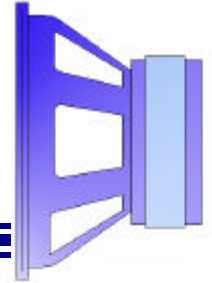

<i>Electroacoustic Specifications</i>	<i>Symbol</i>	<i>Value</i>	<i>Units</i>
Sensitivity	-	93	dB SPL
Normal Power Rating	-	75	Watts
Maximum Input Power	-	150	Watts
Maximum Programme Power	-	300	Watts
Usable Frequency Range	-	Up to 3k5	Hz
Recommended Crossover Frequencies	-	Up to 1k	Hz
Nominal Free Air Resonance	f_s	45	Hz
Mechanical Damping	Q_{MS}	1.23	-
Electromagnetic Damping	Q_{ES}	0.26	-
Total Damping	Q_{TS}	0.21	-
Equivalent Compliance Volume	V_{AS}	77	Litres
Suspension Compliance	C_{MS}	2.1	$\times 10^{-4} \text{m} \cdot \text{N}^{-1}$
Effective Moving Mass	M_{MS}	59	gms
Mechanical Resistance	R_{MS}	14	$\text{N} \cdot \text{s} \cdot \text{m}^{-1}$
Voice Coil Diameter	-	75	mm
Voice Coil Length	-	16	mm
Voice Coil Nominal Resistance	-	5.4	Ohms
Voice Coil Nominal Impedance	-	8	Ohms
Voice Coil Maximum Travel Peak to Peak	-	20	mm
Magnet Total Flux	Φ	2.7	$\times 10^{-3} \text{Wb}$
Magnet Flux Density	B	1.2	Tesla
Magnet B-I product	B-I	19	$\text{N} \cdot \text{A}^{-1}$
Magnet Gap Length	-	10	mm
Magnet Gap Volume	-	3.67	$\times 10^{-6} \text{m}^3$
Diaphragm Effective Area	S_D	550	cm^2
<i>Mechanical Specifications</i>			
Surround Type	-	Rubber	-
Overall Diameter	A	316	mm
Baffle Hole Diameter	B	286	mm
Magnet Diameter	C	181	mm
Front Mount Rebate Depth	D	14	mm
Overall Depth	E	140	mm
Mounting Hole Size	F	8 x M6	-
Mounting Hole P.C.D.	G	300	mm
Shipping Weight	-	8.6	kg
Pack Size	-	36x36x22	cm

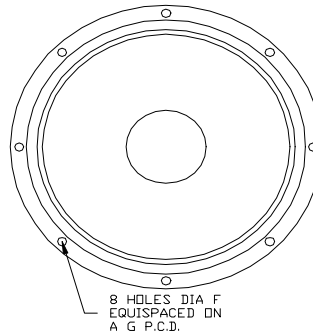
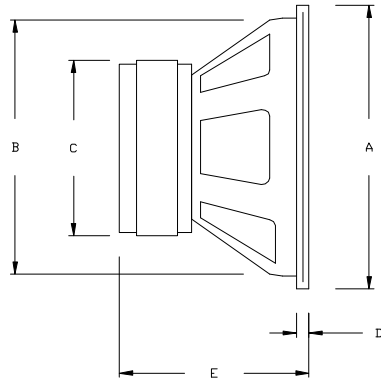

<i>Electroacoustic Specifications</i>	<i>Symbol</i>	<i>Value</i>	<i>Units</i>
Sensitivity	-	89	dB SPL
Normal Power Rating	-	75	Watts
Maximum Input Power	-	150	Watts
Maximum Programme Power	-	300	Watts
Usable Frequency Range	-	Up to 3k	Hz
Recommended Crossover Frequencies	-	Up to 1k	Hz
Nominal Free Air Resonance	f_s	23	Hz
Mechanical Damping	Q_{MS}	1.48	-
Electromagnetic Damping	Q_{ES}	0.32	-
Total Damping	Q_{TS}	0.26	-
Equivalent Compliance Volume	V_{AS}	245	Litres
Suspension Compliance	C_{MS}	6.3	$\times 10^{-4} \text{m} \cdot \text{N}^{-1}$
Effective Moving Mass	M_{MS}	73	gms
Mechanical Resistance	R_{MS}	7	$\text{N} \cdot \text{s} \cdot \text{m}^{-1}$
Voice Coil Diameter	-	75	mm
Voice Coil Length	-	10	mm
Voice Coil Nominal Resistance	-	5.4	Ohms
Voice Coil Nominal Impedance	-	8	Ohms
Voice Coil Maximum Travel Peak to Peak	-	25	mm
Magnet Total Flux	Φ	4.2	$\times 10^{-3} \text{Wb}$
Magnet Flux Density	B	1.0	Tesla
Magnet B-I product	$B \cdot I$	14	$\text{N} \cdot \text{A}^{-1}$
Magnet Gap Length	-	20	mm
Magnet Gap Volume	-	5.78	$\times 10^{-6} \text{m}^3$
Diaphragm Effective Area	S_D	550	cm^2
<i>Mechanical Specifications</i>			
Surround Type	-	Rubber	-
Overall Diameter	A	316	mm
Baffle Hole Diameter	B	286	mm
Magnet Diameter	C	181	mm
Front Mount Rebate Depth	D	14	mm
Overall Depth	E	150	mm
Mounting Hole Size	F	8 x M6	-
Mounting Hole P.C.D.	G	300	mm
Shipping Weight	-	12	kg
Pack Size	-	36x36x22	cm

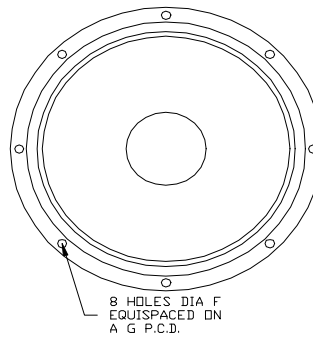
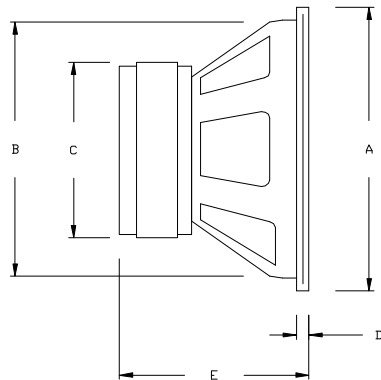
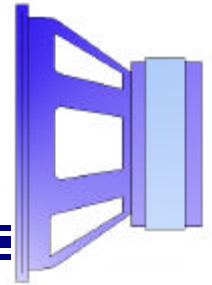

<i>Electroacoustic Specifications</i>	<i>Symbol</i>	<i>Value</i>	<i>Units</i>
Sensitivity	-		dB SPL
Normal Power Rating	-		Watts
Maximum Input Power	-		Watts
Maximum Programme Power	-		Watts
Usable Frequency Range	-		Hz
Recommended Crossover Frequencies	-		Hz
Nominal Free Air Resonance	f_s		Hz
Mechanical Damping	Q_{MS}		-
Electromagnetic Damping	Q_{ES}		-
Total Damping	Q_{TS}		-
Equivalent Compliance Volume	V_{AS}		Litres
Suspension Compliance	C_{MS}		$\times 10^{-4} \text{m} \cdot \text{N}^{-1}$
Effective Moving Mass	M_{MS}		gms
Mechanical Resistance	R_{MS}		$\text{N} \cdot \text{s} \cdot \text{m}^{-1}$
Voice Coil Diameter	-		mm
Voice Coil Length	-		mm
Voice Coil Nominal Resistance	-		Ohms
Voice Coil Nominal Impedance	-		Ohms
Voice Coil Maximum Travel Peak to Peak	-		mm
Magnet Total Flux	Φ		$\times 10^{-3} \text{Wb}$
Magnet Flux Density	B		Tesla
Magnet B-I product	$B \cdot l$		$\text{N} \cdot \text{A}^{-1}$
Magnet Gap Length	-		mm
Magnet Gap Volume	-		$\times 10^{-6} \text{m}^3$
Diaphragm Effective Area	S_D		cm^2
<i>Mechanical Specifications</i>			
Surround Type	-		-
Overall Diameter	A		mm
Baffle Hole Diameter	B		mm
Magnet Diameter	C		mm
Front Mount Rebate Depth	D		mm
Overall Depth	E		mm
Mounting Hole Size	F		-
Mounting Hole P.C.D.	G		mm
Shipping Weight	-		kg
Pack Size	-		cm

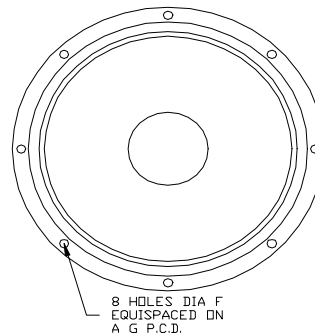
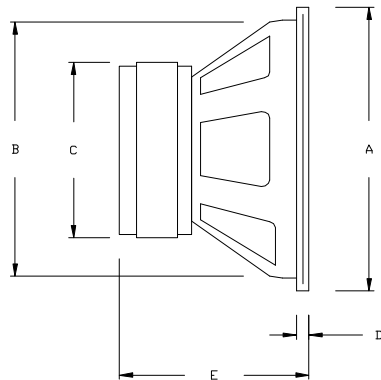
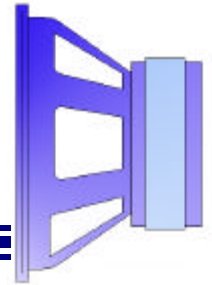

<i>Electroacoustic Specifications</i>	<i>Symbol</i>	<i>Value</i>	<i>Units</i>
Sensitivity	-	99	dB SPL
Normal Power Rating	-	75	Watts
Maximum Input Power	-	150	Watts
Maximum Programme Power	-	300	Watts
Usable Frequency Range	-	Up to 5k	Hz
Recommended Crossover Frequencies	-	Up to 2k	Hz
Nominal Free Air Resonance	f_s	60	Hz
Mechanical Damping	Q_{MS}	3.34	-
Electromagnetic Damping	Q_{ES}	0.45	-
Total Damping	Q_{TS}	0.40	-
Equivalent Compliance Volume	V_{AS}	82	Litres
Suspension Compliance	C_{MS}	1.1	$\times 10^{-4} \text{m} \cdot \text{N}^{-1}$
Effective Moving Mass	M_{MS}	62	gms
Mechanical Resistance	R_{MS}	7	$\text{N} \cdot \text{s} \cdot \text{m}^{-1}$
Voice Coil Diameter	-	75	mm
Voice Coil Length	-	10	mm
Voice Coil Nominal Resistance	-	5.4	Ohms
Voice Coil Nominal Impedance	-	8	Ohms
Voice Coil Maximum Travel Peak to Peak	-	25	mm
Magnet Total Flux	Φ	3.1	$\times 10^{-3} \text{Wb}$
Magnet Flux Density	B	1.4	Tesla
Magnet B-I product	$B \cdot l$	16	$\text{N} \cdot \text{A}^{-1}$
Magnet Gap Length	-	10	mm
Magnet Gap Volume	-	2.92	$\times 10^{-6} \text{m}^3$
Diaphragm Effective Area	S_D	820	cm^2
<i>Mechanical Specifications</i>			
Surround Type	-	Fabric	-
Overall Diameter	A	390	mm
Baffle Hole Diameter	B	348	mm
Magnet Diameter	C	181	mm
Front Mount Rebate Depth	D	15	mm
Overall Depth	E	154	mm
Mounting Hole Size	F	8 x M6	-
Mounting Hole P.C.D.	G	370	mm
Shipping Weight	-	13.63	kg
Pack Size	-	46x46x22	cm

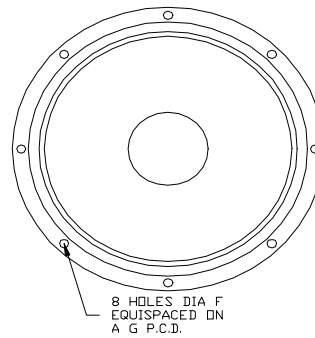
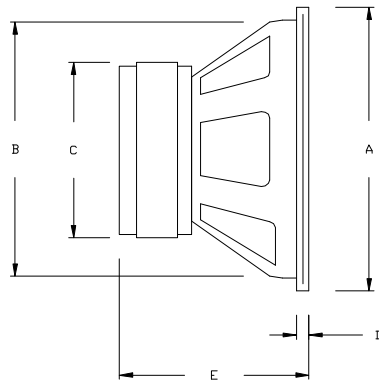
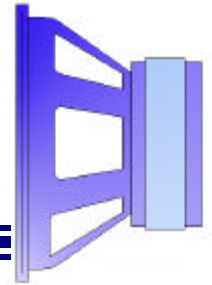

<i>Electroacoustic Specifications</i>	<i>Symbol</i>	<i>Value</i>	<i>Units</i>
Sensitivity	-	97	dB SPL
Normal Power Rating	-	75	Watts
Maximum Input Power	-	150	Watts
Maximum Programme Power	-	300	Watts
Usable Frequency Range	-	Up to 3k	Hz
Recommended Crossover Frequencies	-	Up to 800	Hz
Nominal Free Air Resonance	f_s	41	Hz
Mechanical Damping	Q_{MS}	1.65	-
Electromagnetic Damping	Q_{ES}	0.45	-
Total Damping	Q_{TS}	0.35	-
Equivalent Compliance Volume	V_{AS}	155	Litres
Suspension Compliance	C_{MS}	2.0	$\times 10^{-4} \text{m} \cdot \text{N}^{-1}$
Effective Moving Mass	M_{MS}	74	gms
Mechanical Resistance	R_{MS}	12	$\text{N} \cdot \text{s} \cdot \text{m}^{-1}$
Voice Coil Diameter	-	75	mm
Voice Coil Length	-	14	mm
Voice Coil Nominal Resistance	-	5.4	Ohms
Voice Coil Nominal Impedance	-	8	Ohms
Voice Coil Maximum Travel Peak to Peak	-	25	mm
Magnet Total Flux	Φ	2.7	$\times 10^{-3} \text{Wb}$
Magnet Flux Density	B	1.2	Tesla
Magnet B-I product	B-I	15	$\text{N} \cdot \text{A}^{-1}$
Magnet Gap Length	-	10	mm
Magnet Gap Volume	-	3.67	$\times 10^{-6} \text{m}^3$
Diaphragm Effective Area	S_D	820	cm^2
<i>Mechanical Specifications</i>			
Surround Type	-	Fabric	-
Overall Diameter	A	390	mm
Baffle Hole Diameter	B	348	mm
Magnet Diameter	C	181	mm
Front Mount Rebate Depth	D	15	mm
Overall Depth	E	154	mm
Mounting Hole Size	F	8 x M6	-
Mounting Hole P.C.D.	G	370	mm
Shipping Weight	-	13.63	kg
Pack Size	-	46x46x22	cm

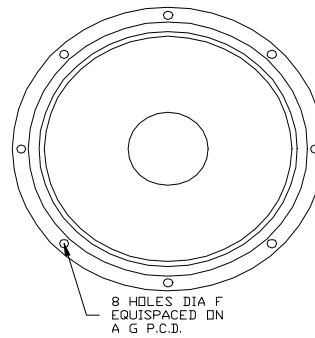
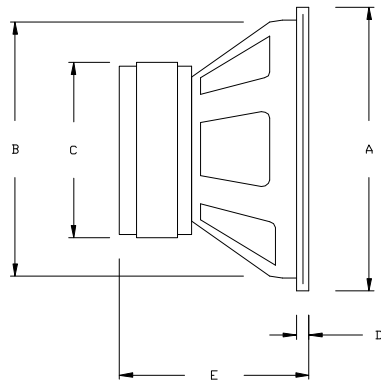

<i>Electroacoustic Specifications</i>	<i>Symbol</i>	<i>Value</i>	<i>Units</i>
Sensitivity	-	99	dB SPL
Normal Power Rating	-	75	Watts
Maximum Input Power	-	150	Watts
Maximum Programme Power	-	300	Watts
Usable Frequency Range	-	Up to 3k	Hz
Recommended Crossover Frequencies	-	Up to 800	Hz
Nominal Free Air Resonance	f_s	53	Hz
Mechanical Damping	Q_{MS}	1.83	-
Electromagnetic Damping	Q_{ES}	0.41	-
Total Damping	Q_{TS}	0.33	-
Equivalent Compliance Volume	V_{AS}	87	Litres
Suspension Compliance	C_{MS}	1.1	$\times 10^{-4} \text{m} \cdot \text{N}^{-1}$
Effective Moving Mass	M_{MS}	79	gms
Mechanical Resistance	R_{MS}	14	$\text{N} \cdot \text{s} \cdot \text{m}^{-1}$
Voice Coil Diameter	-	75	mm
Voice Coil Length	-	16	mm
Voice Coil Nominal Resistance	-	5.4	Ohms
Voice Coil Nominal Impedance	-	8	Ohms
Voice Coil Maximum Travel Peak to Peak	-	25	mm
Magnet Total Flux	Φ	2.7	$\times 10^{-3} \text{Wb}$
Magnet Flux Density	B	1.2	Tesla
Magnet B-I product	B-I	18	$\text{N} \cdot \text{A}^{-1}$
Magnet Gap Length	-	10	mm
Magnet Gap Volume	-	3.67	$\times 10^{-6} \text{m}^3$
Diaphragm Effective Area	S_D	820	cm^2
<i>Mechanical Specifications</i>			
Surround Type	-	Fabric	-
Overall Diameter	A	390	mm
Baffle Hole Diameter	B	348	mm
Magnet Diameter	C	181	mm
Front Mount Rebate Depth	D	15	mm
Overall Depth	E	154	mm
Mounting Hole Size	F	8 x M6	-
Mounting Hole P.C.D.	G	370	mm
Shipping Weight	-	13.63	kg
Pack Size	-	46x46x22	cm

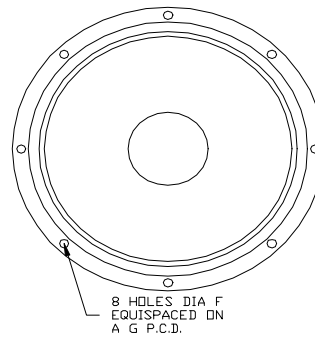
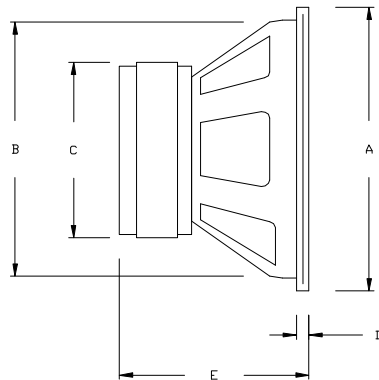
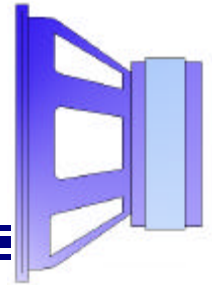

<i>Electroacoustic Specifications</i>	<i>Symbol</i>	<i>Value</i>	<i>Units</i>
Sensitivity	-	92	dB SPL
Normal Power Rating	-	75	Watts
Maximum Input Power	-	150	Watts
Maximum Programme Power	-	300	Watts
Usable Frequency Range	-	Up to 3k	Hz
Recommended Crossover Frequencies	-	Up to 1k	Hz
Nominal Free Air Resonance	f_s	23	Hz
Mechanical Damping	Q_{MS}	1.59	-
Electromagnetic Damping	Q_{ES}	0.35	-
Total Damping	Q_{TS}	0.28	-
Equivalent Compliance Volume	V_{AS}	486	Litres
Suspension Compliance	C_{MS}	6.5	$\times 10^{-4} \text{m} \cdot \text{N}^{-1}$
Effective Moving Mass	M_{MS}	75	gms
Mechanical Resistance	R_{MS}	7	$\text{N} \cdot \text{s} \cdot \text{m}^{-1}$
Voice Coil Diameter	-	75	mm
Voice Coil Length	-	10	mm
Voice Coil Nominal Resistance	-	5.4	Ohms
Voice Coil Nominal Impedance	-	8	Ohms
Voice Coil Maximum Travel Peak to Peak	-	25	mm
Magnet Total Flux	Φ	3.8	$\times 10^{-3} \text{Wb}$
Magnet Flux Density	B	1.0	Tesla
Magnet B-I product	$B \cdot l$	14	$\text{N} \cdot \text{A}^{-1}$
Magnet Gap Length	-	16	mm
Magnet Gap Volume	-	4.62	$\times 10^{-6} \text{m}^3$
Diaphragm Effective Area	S_D	820	cm^2
<i>Mechanical Specifications</i>			
Surround Type	-	Foam	-
Overall Diameter	A	390	mm
Baffle Hole Diameter	B	348	mm
Magnet Diameter	C	181	mm
Front Mount Rebate Depth	D	15	mm
Overall Depth	E	160	mm
Mounting Hole Size	F	8 x M6	-
Mounting Hole P.C.D.	G	370	mm
Shipping Weight	-	15	kg
Pack Size	-	46x46x22	cm

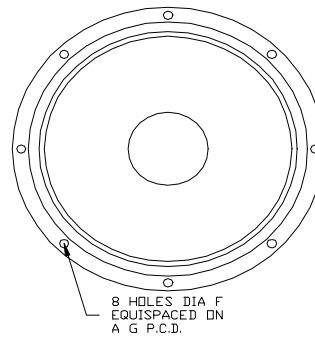
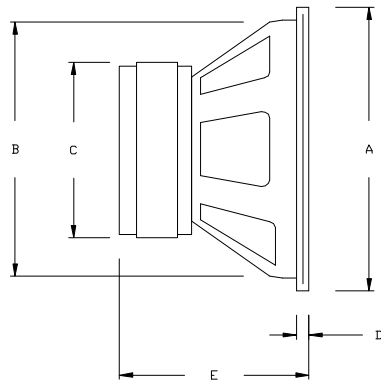
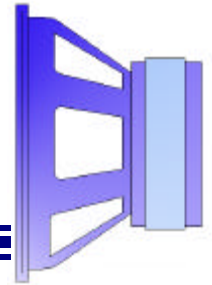

<i>Electroacoustic Specifications</i>	<i>Symbol</i>	<i>Value</i>	<i>Units</i>
Sensitivity	-	91	dB SPL
Normal Power Rating	-	75	Watts
Maximum Input Power	-	150	Watts
Maximum Programme Power	-	300	Watts
Usable Frequency Range	-	Up to 3k	Hz
Recommended Crossover Frequencies	-	Up to 1k	Hz
Nominal Free Air Resonance	f_s	26	Hz
Mechanical Damping	Q_{MS}	2.12	-
Electromagnetic Damping	Q_{ES}	0.46	-
Total Damping	Q_{TS}	0.38	-
Equivalent Compliance Volume	V_{AS}	358	Litres
Suspension Compliance	C_{MS}	4.0	$\times 10^{-4} \text{m} \cdot \text{N}^{-1}$
Effective Moving Mass	M_{MS}	91	gms
Mechanical Resistance	R_{MS}	7	$\text{N} \cdot \text{s} \cdot \text{m}^{-1}$
Voice Coil Diameter	-	75	mm
Voice Coil Length	-	16	mm
Voice Coil Nominal Resistance	-	5.4	Ohms
Voice Coil Nominal Impedance	-	8	Ohms
Voice Coil Maximum Travel Peak to Peak	-	25	mm
Magnet Total Flux	Φ	2.7	$\times 10^{-3} \text{Wb}$
Magnet Flux Density	B	1.2	Tesla
Magnet B-I product	$B \cdot l$	14	$\text{N} \cdot \text{A}^{-1}$
Magnet Gap Length	-	10	mm
Magnet Gap Volume	-	3.67	$\times 10^{-6} \text{m}^3$
Diaphragm Effective Area	S_D	820	cm^2
<i>Mechanical Specifications</i>			
Surround Type	-	Foam	-
Overall Diameter	A	390	mm
Baffle Hole Diameter	B	348	mm
Magnet Diameter	C	181	mm
Front Mount Rebate Depth	D	15	mm
Overall Depth	E	154	mm
Mounting Hole Size	F	8 x M6	-
Mounting Hole P.C.D.	G	370	mm
Shipping Weight	-	13	kg
Pack Size	-	46x46x23	cm

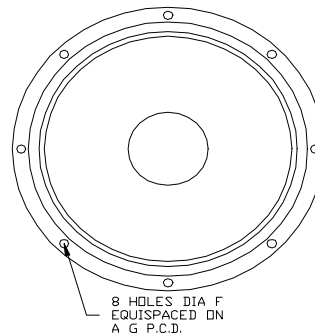
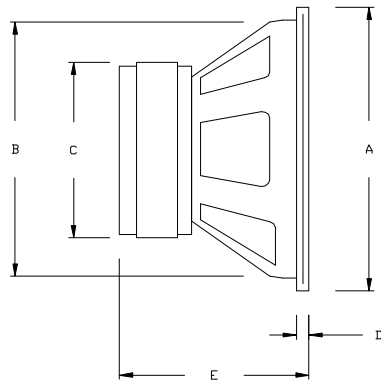
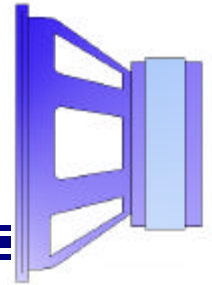

<i>Electroacoustic Specifications</i>	<i>Symbol</i>	<i>Value</i>	<i>Units</i>
Sensitivity	-		dB SPL
Normal Power Rating	-		Watts
Maximum Input Power	-		Watts
Maximum Programme Power	-		Watts
Usable Frequency Range	-		Hz
Recommended Crossover Frequencies	-		Hz
Nominal Free Air Resonance	f_s		Hz
Mechanical Damping	Q_{MS}		-
Electromagnetic Damping	Q_{ES}		-
Total Damping	Q_{TS}		-
Equivalent Compliance Volume	V_{AS}		Litres
Suspension Compliance	C_{MS}		$\times 10^{-4} \text{m} \cdot \text{N}^{-1}$
Effective Moving Mass	M_{MS}		gms
Mechanical Resistance	R_{MS}		$\text{N} \cdot \text{s} \cdot \text{m}^{-1}$
Voice Coil Diameter	-		mm
Voice Coil Length	-		mm
Voice Coil Nominal Resistance	-		Ohms
Voice Coil Nominal Impedance	-		Ohms
Voice Coil Maximum Travel Peak to Peak	-		mm
Magnet Total Flux	Φ		$\times 10^{-3} \text{Wb}$
Magnet Flux Density	B		Tesla
Magnet B-I product	$B \cdot l$		$\text{N} \cdot \text{A}^{-1}$
Magnet Gap Length	-		mm
Magnet Gap Volume	-		$\times 10^{-6} \text{m}^3$
Diaphragm Effective Area	S_D		cm^2
<i>Mechanical Specifications</i>			
Surround Type	-		-
Overall Diameter	A		mm
Baffle Hole Diameter	B		mm
Magnet Diameter	C		mm
Front Mount Rebate Depth	D		mm
Overall Depth	E		mm
Mounting Hole Size	F		-
Mounting Hole P.C.D.	G		mm
Shipping Weight	-		kg
Pack Size	-		cm

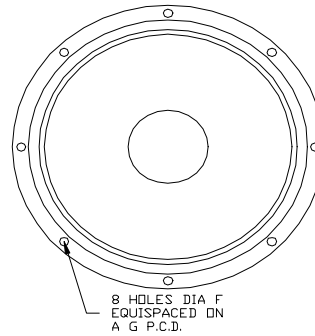
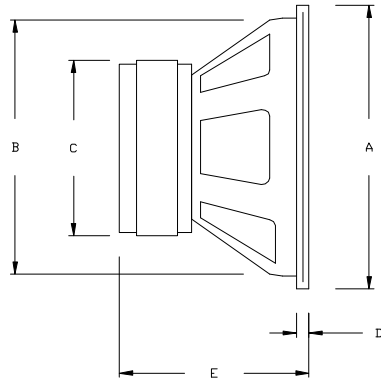
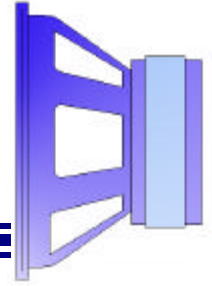

<i>Electroacoustic Specifications</i>	<i>Symbol</i>	<i>Value</i>	<i>Units</i>
Sensitivity	-	100	dB SPL
Normal Power Rating	-	100	Watts
Maximum Input Power	-	200	Watts
Maximum Programme Power	-	400	Watts
Usable Frequency Range	-	Up to 3k	Hz
Recommended Crossover Frequencies	-	Up to 2k	Hz
Nominal Free Air Resonance	f_s	47	Hz
Mechanical Damping	Q_{MS}	2.92	-
Electromagnetic Damping	Q_{ES}	0.24	-
Total Damping	Q_{TS}	0.22	-
Equivalent Compliance Volume	V_{AS}	118	Litres
Suspension Compliance	C_{MS}	1.3	$\times 10^{-4} \text{m} \cdot \text{N}^{-1}$
Effective Moving Mass	M_{MS}	89	gms
Mechanical Resistance	R_{MS}	9	$\text{N} \cdot \text{s} \cdot \text{m}^{-1}$
Voice Coil Diameter	-	100	mm
Voice Coil Length	-	8	mm
Voice Coil Nominal Resistance	-	5.4	Ohms
Voice Coil Nominal Impedance	-	8	Ohms
Voice Coil Maximum Travel Peak to Peak	-	25	mm
Magnet Total Flux	Φ	4.3	$\times 10^{-3} \text{Wb}$
Magnet Flux Density	B	1.5	Tesla
Magnet B-I product	$B \cdot l$	22	$\text{N} \cdot \text{A}^{-1}$
Magnet Gap Length	-	8	mm
Magnet Gap Volume	-	3.51	$\times 10^{-6} \text{m}^3$
Diaphragm Effective Area	S_D	900	cm^2
<i>Mechanical Specifications</i>			
Surround Type	-	Fabric	-
Overall Diameter	A	396	mm
Baffle Hole Diameter	B	355	mm
Magnet Diameter	C	220	mm
Front Mount Rebate Depth	D	15	mm
Overall Depth	E	145	mm
Mounting Hole Size	F	8 x M6	-
Mounting Hole P.C.D.	G	370	mm
Shipping Weight	-	17	kg
Pack Size	-	46x46x22	cm

PA100-375 BASS

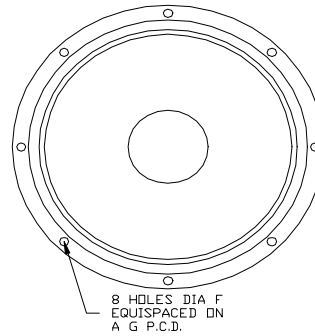
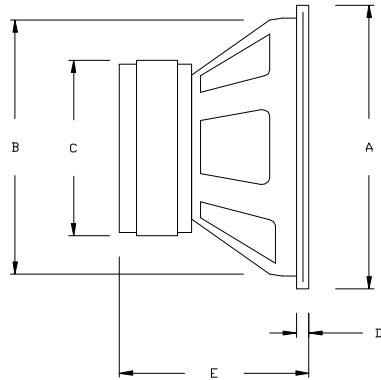
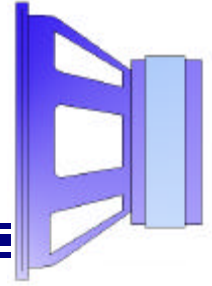

<i>Electroacoustic Specifications</i>	<i>Symbol</i>	<i>Value</i>	<i>Units</i>
Sensitivity	-	99	dB SPL
Normal Power Rating	-	100	Watts
Maximum Input Power	-	200	Watts
Maximum Programme Power	-	400	Watts
Usable Frequency Range	-	Up to 2k	Hz
Recommended Crossover Frequencies	-	Up to 800	Hz
Nominal Free Air Resonance	f_s	50	Hz
Mechanical Damping	Q_{MS}	1.40	-
Electromagnetic Damping	Q_{ES}	0.26	-
Total Damping	Q_{TS}	0.22	-
Equivalent Compliance Volume	V_{AS}	106	Litres
Suspension Compliance	C_{MS}	1.1	$\times 10^{-4} \text{m} \cdot \text{N}^{-1}$
Effective Moving Mass	M_{MS}	94	gms
Mechanical Resistance	R_{MS}	21	$\text{N} \cdot \text{s} \cdot \text{m}^{-1}$
Voice Coil Diameter	-	100	mm
Voice Coil Length	-	11.5	mm
Voice Coil Nominal Resistance	-	5.4	Ohms
Voice Coil Nominal Impedance	-	8	Ohms
Voice Coil Maximum Travel Peak to Peak	-	25	mm
Magnet Total Flux	Φ	3.7	$\times 10^{-3} \text{Wb}$
Magnet Flux Density	B	1.4	Tesla
Magnet B-I product	$B \cdot l$	22	$\text{N} \cdot \text{A}^{-1}$
Magnet Gap Length	-	8	mm
Magnet Gap Volume	-	4.47	$\times 10^{-6} \text{m}^3$
Diaphragm Effective Area	S_D	900	cm^2
<i>Mechanical Specifications</i>			
Surround Type	-	Fabric	-
Overall Diameter	A	396	mm
Baffle Hole Diameter	B	355	mm
Magnet Diameter	C	220	mm
Front Mount Rebate Depth	D	15	mm
Overall Depth	E	145	mm
Mounting Hole Size	F	8 x M6	-
Mounting Hole P.C.D.	G	370	mm
Shipping Weight	-	17	kg
Pack Size	-	46x46x22	cm

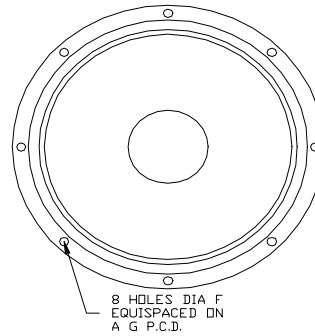
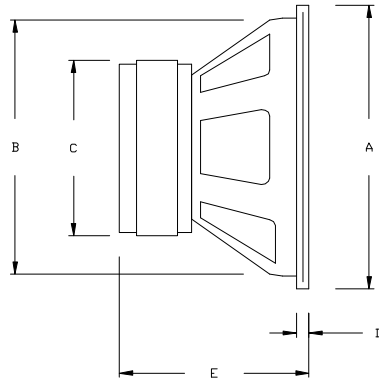
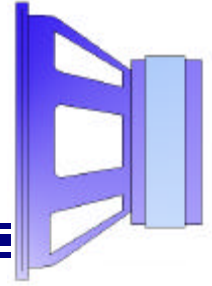

<i>Electroacoustic Specifications</i>	<i>Symbol</i>	<i>Value</i>	<i>Units</i>
Sensitivity	-	98	dB SPL
Normal Power Rating	-	100	Watts
Maximum Input Power	-	200	Watts
Maximum Programme Power	-	400	Watts
Usable Frequency Range	-	Up to 2k	Hz
Recommended Crossover Frequencies	-	Up to 800	Hz
Nominal Free Air Resonance	f_s	44	Hz
Mechanical Damping	Q_{MS}	1.20	-
Electromagnetic Damping	Q_{ES}	0.27	-
Total Damping	Q_{TS}	0.22	-
Equivalent Compliance Volume	V_{AS}	134	Litres
Suspension Compliance	C_{MS}	1.4	$\times 10^{-4} \text{m} \cdot \text{N}^{-1}$
Effective Moving Mass	M_{MS}	95	gms
Mechanical Resistance	R_{MS}	22	$\text{N} \cdot \text{s} \cdot \text{m}^{-1}$
Voice Coil Diameter	-	100	mm
Voice Coil Length	-	14	mm
Voice Coil Nominal Resistance	-	5.4	Ohms
Voice Coil Nominal Impedance	-	8	Ohms
Voice Coil Maximum Travel Peak to Peak	-	25	mm
Magnet Total Flux	Φ	3.7	$\times 10^{-3} \text{Wb}$
Magnet Flux Density	B	1.3	Tesla
Magnet B-I product	$B \cdot l$	20	$\text{N} \cdot \text{A}^{-1}$
Magnet Gap Length	-	8	mm
Magnet Gap Volume	-	4.47	$\times 10^{-6} \text{m}^3$
Diaphragm Effective Area	S_D	900	cm^2
<i>Mechanical Specifications</i>			
Surround Type	-	Fabric	-
Overall Diameter	A	396	mm
Baffle Hole Diameter	B	355	mm
Magnet Diameter	C	220	mm
Front Mount Rebate Depth	D	15	mm
Overall Depth	E	145	mm
Mounting Hole Size	F	8 x M6	-
Mounting Hole P.C.D.	G	370	mm
Shipping Weight	-	17	kg
Pack Size	-	46x46x22	cm

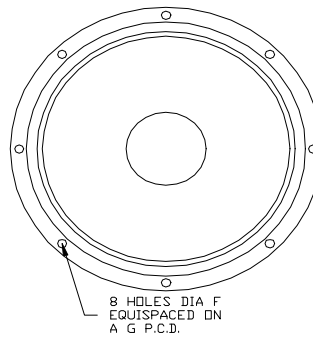
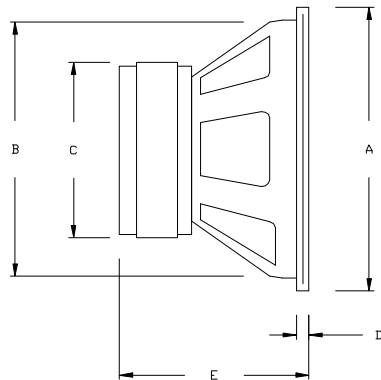
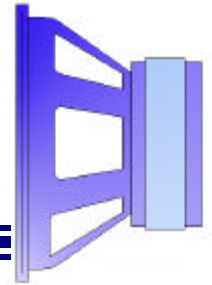

<i>Electroacoustic Specifications</i>	<i>Symbol</i>	<i>Value</i>	<i>Units</i>
Sensitivity	-	91	dB SPL
Normal Power Rating	-	100	Watts
Maximum Input Power	-	200	Watts
Maximum Programme Power	-	400	Watts
Usable Frequency Range	-	Up to 3k	Hz
Recommended Crossover Frequencies	-	Up to 1k	Hz
Nominal Free Air Resonance	f_s	26	Hz
Mechanical Damping	Q_{MS}	1.18	-
Electromagnetic Damping	Q_{ES}	0.30	-
Total Damping	Q_{TS}	0.24	-
Equivalent Compliance Volume	V_{AS}	364	Litres
Suspension Compliance	C_{MS}	3.7	$\times 10^{-4} \text{m} \cdot \text{N}^{-1}$
Effective Moving Mass	M_{MS}	98	gms
Mechanical Resistance	R_{MS}	14	$\text{N} \cdot \text{s} \cdot \text{m}^{-1}$
Voice Coil Diameter	-	100	mm
Voice Coil Length	-	8	mm
Voice Coil Nominal Resistance	-	5.4	Ohms
Voice Coil Nominal Impedance	-	8	Ohms
Voice Coil Maximum Travel Peak to Peak	-	25	mm
Magnet Total Flux	Φ	6.0	$\times 10^{-3} \text{Wb}$
Magnet Flux Density	B	1.0	Tesla
Magnet B-I product	$B \cdot l$	16	$\text{N} \cdot \text{A}^{-1}$
Magnet Gap Length	-	16	mm
Magnet Gap Volume	-	7.01	$\times 10^{-6} \text{m}^3$
Diaphragm Effective Area	S_D	900	cm^2
<i>Mechanical Specifications</i>			
Surround Type	-	Rubber	-
Overall Diameter	A	396	mm
Baffle Hole Diameter	B	355	mm
Magnet Diameter	C	220	mm
Front Mount Rebate Depth	D	15	mm
Overall Depth	E	150	mm
Mounting Hole Size	F	8 x M6	-
Mounting Hole P.C.D.	G	370	mm
Shipping Weight	-	18.18	kg
Pack Size	-	46x46x22	cm

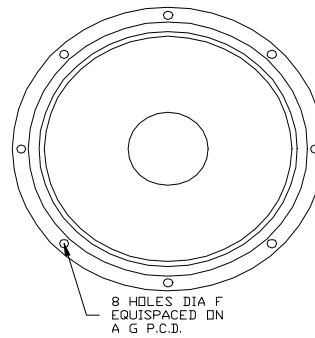
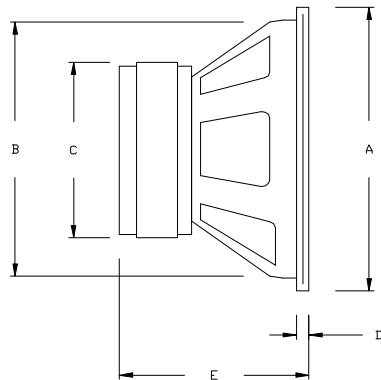
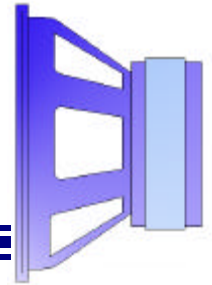

<i>Electroacoustic Specifications</i>	<i>Symbol</i>	<i>Value</i>	<i>Units</i>
Sensitivity	-	91	dB SPL
Normal Power Rating	-	100	Watts
Maximum Input Power	-	200	Watts
Maximum Programme Power	-	400	Watts
Usable Frequency Range	-	Up to 3k	Hz
Recommended Crossover Frequencies	-	Up to 1k	Hz
Nominal Free Air Resonance	f_s	24	Hz
Mechanical Damping	Q_{MS}	1.09	-
Electromagnetic Damping	Q_{ES}	0.17	-
Total Damping	Q_{TS}	0.15	-
Equivalent Compliance Volume	V_{AS}	353	Litres
Suspension Compliance	C_{MS}	3.7	$\times 10^{-4} \text{m} \cdot \text{N}^{-1}$
Effective Moving Mass	M_{MS}	116	gms
Mechanical Resistance	R_{MS}	16	$\text{N} \cdot \text{s} \cdot \text{m}^{-1}$
Voice Coil Diameter	-	100	mm
Voice Coil Length	-	16	mm
Voice Coil Nominal Resistance	-	5.4	Ohms
Voice Coil Nominal Impedance	-	8	Ohms
Voice Coil Maximum Travel Peak to Peak	-	25	mm
Magnet Total Flux	Φ	4.2	$\times 10^{-3} \text{Wb}$
Magnet Flux Density	B	1.3	Tesla
Magnet B-I product	$B \cdot l$	20	$\text{N} \cdot \text{A}^{-1}$
Magnet Gap Length	-	10	mm
Magnet Gap Volume	-	5.59	$\times 10^{-6} \text{m}^3$
Diaphragm Effective Area	S_D	900	cm^2
<i>Mechanical Specifications</i>			
Surround Type	-	Rubber	-
Overall Diameter	A	396	mm
Baffle Hole Diameter	B	355	mm
Magnet Diameter	C	220	mm
Front Mount Rebate Depth	D	15	mm
Overall Depth	E	144	mm
Mounting Hole Size	F	8 x M6	-
Mounting Hole P.C.D.	G	370	mm
Shipping Weight	-	16.5	kg
Pack Size	-	46x46x22	cm

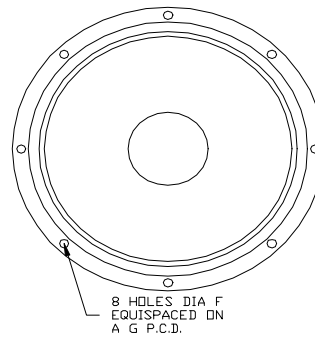
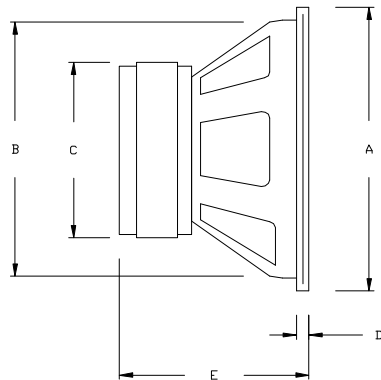
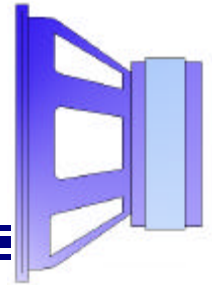

<i>Electroacoustic Specifications</i>	<i>Symbol</i>	<i>Value</i>	<i>Units</i>
Sensitivity	-	91	dB SPL
Normal Power Rating	-	75	Watts
Maximum Input Power	-	150	Watts
Maximum Programme Power	-	300	Watts
Usable Frequency Range	-	Up to 5k	Hz
Recommended Crossover Frequencies	-	380 to 3k8	Hz
Nominal Free Air Resonance	f_s	320	Hz
Mechanical Damping	Q_{MS}	15.5	-
Electromagnetic Damping	Q_{ES}	0.76	-
Total Damping	Q_{TS}	0.72	-
Equivalent Compliance Volume	V_{AS}	0.09	Litres
Suspension Compliance	C_{MS}	0.26	$\times 10^{-4} \text{m} \cdot \text{N}^{-1}$
Effective Moving Mass	M_{MS}	9.5	gms
Mechanical Resistance	R_{MS}	1.2	$\text{N} \cdot \text{s} \cdot \text{m}^{-1}$
Voice Coil Diameter	-	75	mm
Voice Coil Length	-	3.5	mm
Voice Coil Nominal Resistance	-	10.5	Ohms
Voice Coil Nominal Impedance	-	16	Ohms
Voice Coil Maximum Travel Peak to Peak	-	6	mm
Magnet Total Flux	Φ	1.9	$\times 10^{-3} \text{Wb}$
Magnet Flux Density	B	1.6	Tesla
Magnet B-I product	$B \cdot l$	16.5	$\text{N} \cdot \text{A}^{-1}$
Magnet Gap Length	-	5	mm
Magnet Gap Volume	-	0.65	$\times 10^{-6} \text{m}^3$
Diaphragm Effective Area	S_D	50	cm^2
<i>Mechanical Specifications</i>			
Surround Type	-	Fabric	-
Overall Diameter	A	196	mm
Baffle Hole Diameter	B	154	mm
Magnet Diameter	C	156	mm
Front Mount Rebate Depth	D	-	mm
Overall Depth	E	94	mm
Mounting Hole Size	F	M6	-
Mounting Hole P.C.D.	G	172	mm
Shipping Weight	-	7	kg
Pack Size	-	25x25x16	cm

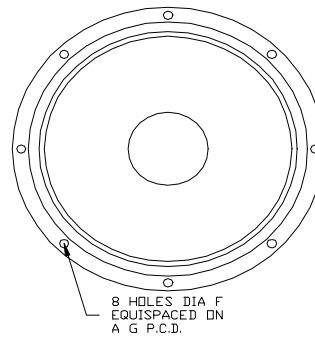
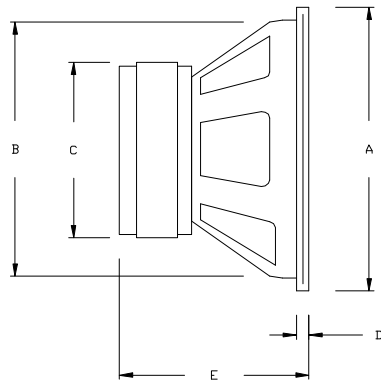
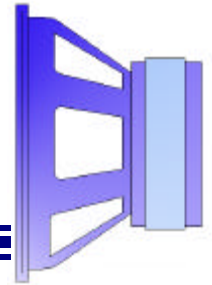

<i>Electroacoustic Specifications</i>	<i>Symbol</i>	<i>Value</i>	<i>Units</i>
Sensitivity	-	94	dB SPL
Normal Power Rating	-	75	Watts
Maximum Input Power	-	150	Watts
Maximum Programme Power	-	300	Watts
Usable Frequency Range	-	Up to 5k	Hz
Recommended Crossover Frequencies	-	381 to 3k8	Hz
Nominal Free Air Resonance	f_s	320	Hz
Mechanical Damping	Q_{MS}	-	-
Electromagnetic Damping	Q_{ES}	-	-
Total Damping	Q_{TS}	-	-
Equivalent Compliance Volume	V_{AS}	-	Litres
Suspension Compliance	C_{MS}	-	$\times 10^{-4} \text{m} \cdot \text{N}^{-1}$
Effective Moving Mass	M_{MS}	-	gms
Mechanical Resistance	R_{MS}	-	$\text{N} \cdot \text{s} \cdot \text{m}^{-1}$
Voice Coil Diameter	-	75	mm
Voice Coil Length	-	3.5	mm
Voice Coil Nominal Resistance	-	10.5	Ohms
Voice Coil Nominal Impedance	-	16	Ohms
Voice Coil Maximum Travel Peak to Peak	-	6	mm
Magnet Total Flux	Φ	2.5	$\times 10^{-3} \text{Wb}$
Magnet Flux Density	B	2.1	Tesla
Magnet B-I product	$B \cdot l$	-	$\text{N} \cdot \text{A}^{-1}$
Magnet Gap Length	-	5	mm
Magnet Gap Volume	-	-	$\times 10^{-6} \text{m}^3$
Diaphragm Effective Area	S_D	50	cm^2
<i>Mechanical Specifications</i>			
Surround Type	-	Fabric	-
Overall Diameter	A	196	mm
Baffle Hole Diameter	B	154	mm
Magnet Diameter	C	181	mm
Front Mount Rebate Depth	D	-	mm
Overall Depth	E	92	mm
Mounting Hole Size	F	M6	-
Mounting Hole P.C.D.	G	172	mm
Shipping Weight	-	9	kg
Pack Size	-	25x25x17	cm

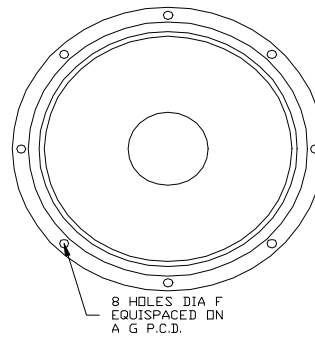
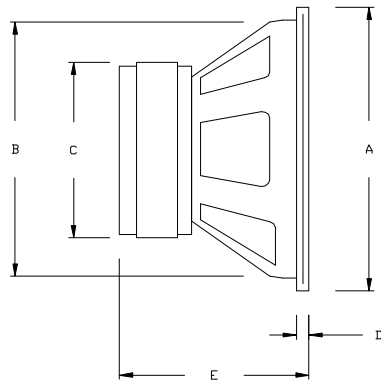
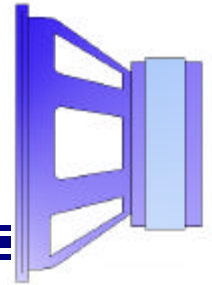

<i>Electroacoustic Specifications</i>	<i>Symbol</i>	<i>Value</i>	<i>Units</i>
Sensitivity	-		dB SPL
Normal Power Rating	-		Watts
Maximum Input Power	-		Watts
Maximum Programme Power	-		Watts
Usable Frequency Range	-		Hz
Recommended Crossover Frequencies	-		Hz
Nominal Free Air Resonance	f_s		Hz
Mechanical Damping	Q_{MS}		-
Electromagnetic Damping	Q_{ES}		-
Total Damping	Q_{TS}		-
Equivalent Compliance Volume	V_{AS}		Litres
Suspension Compliance	C_{MS}		$\times 10^{-4} \text{m} \cdot \text{N}^{-1}$
Effective Moving Mass	M_{MS}		gms
Mechanical Resistance	R_{MS}		$\text{N} \cdot \text{s} \cdot \text{m}^{-1}$
Voice Coil Diameter	-		mm
Voice Coil Length	-		mm
Voice Coil Nominal Resistance	-		Ohms
Voice Coil Nominal Impedance	-		Ohms
Voice Coil Maximum Travel Peak to Peak	-		mm
Magnet Total Flux	Φ		$\times 10^{-3} \text{Wb}$
Magnet Flux Density	B		Tesla
Magnet B-I product	$B \cdot I$		$\text{N} \cdot \text{A}^{-1}$
Magnet Gap Length	-		mm
Magnet Gap Volume	-		$\times 10^{-6} \text{m}^3$
Diaphragm Effective Area	S_D		cm^2
<i>Mechanical Specifications</i>			
Surround Type	-		-
Overall Diameter	A		mm
Baffle Hole Diameter	B		mm
Magnet Diameter	C		mm
Front Mount Rebate Depth	D		mm
Overall Depth	E		mm
Mounting Hole Size	F		-
Mounting Hole P.C.D.	G		mm
Shipping Weight	-		kg
Pack Size	-		cm

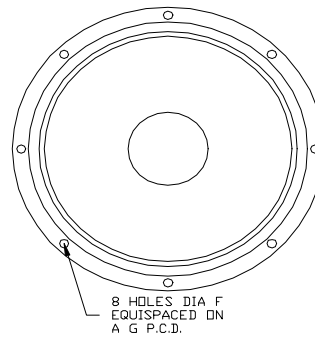
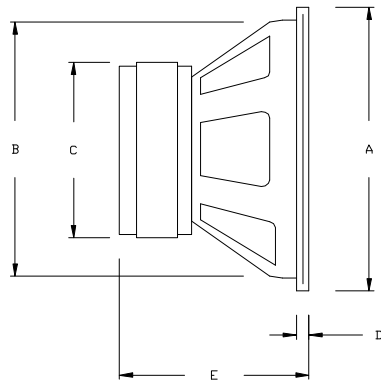
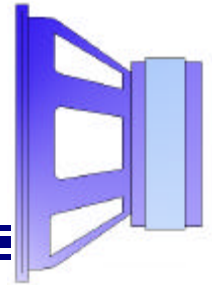

<i>Electroacoustic Specifications</i>	<i>Symbol</i>	<i>Value</i>	<i>Units</i>
Sensitivity	-		dB SPL
Normal Power Rating	-		Watts
Maximum Input Power	-		Watts
Maximum Programme Power	-		Watts
Usable Frequency Range	-		Hz
Recommended Crossover Frequencies	-		Hz
Nominal Free Air Resonance	f_s		Hz
Mechanical Damping	Q_{MS}		-
Electromagnetic Damping	Q_{ES}		-
Total Damping	Q_{TS}		-
Equivalent Compliance Volume	V_{AS}		Litres
Suspension Compliance	C_{MS}		$\times 10^{-4} \text{m} \cdot \text{N}^{-1}$
Effective Moving Mass	M_{MS}		gms
Mechanical Resistance	R_{MS}		$\text{N} \cdot \text{s} \cdot \text{m}^{-1}$
Voice Coil Diameter	-		mm
Voice Coil Length	-		mm
Voice Coil Nominal Resistance	-		Ohms
Voice Coil Nominal Impedance	-		Ohms
Voice Coil Maximum Travel Peak to Peak	-		mm
Magnet Total Flux	Φ		$\times 10^{-3} \text{Wb}$
Magnet Flux Density	B		Tesla
Magnet B-I product	$B \cdot l$		$\text{N} \cdot \text{A}^{-1}$
Magnet Gap Length	-		mm
Magnet Gap Volume	-		$\times 10^{-6} \text{m}^3$
Diaphragm Effective Area	S_D		cm^2
<i>Mechanical Specifications</i>			
Surround Type	-		-
Overall Diameter	A		mm
Baffle Hole Diameter	B		mm
Magnet Diameter	C		mm
Front Mount Rebate Depth	D		mm
Overall Depth	E		mm
Mounting Hole Size	F		-
Mounting Hole P.C.D.	G		mm
Shipping Weight	-		kg
Pack Size	-		cm

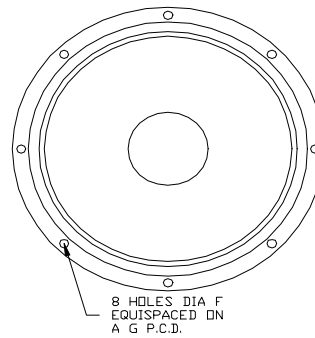
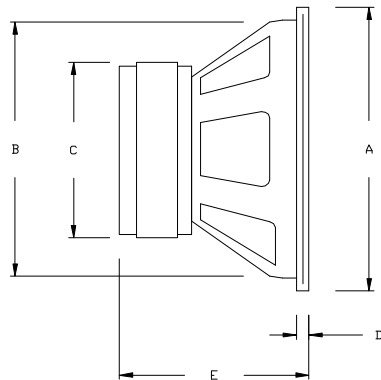
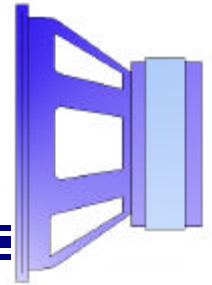

<i>Electroacoustic Specifications</i>	<i>Symbol</i>	<i>Value</i>	<i>Units</i>
Sensitivity	-		dB SPL
Normal Power Rating	-		Watts
Maximum Input Power	-		Watts
Maximum Programme Power	-		Watts
Usable Frequency Range	-		Hz
Recommended Crossover Frequencies	-		Hz
Nominal Free Air Resonance	f_s		Hz
Mechanical Damping	Q_{MS}		-
Electromagnetic Damping	Q_{ES}		-
Total Damping	Q_{TS}		-
Equivalent Compliance Volume	V_{AS}		Litres
Suspension Compliance	C_{MS}		$\times 10^{-4} \text{m} \cdot \text{N}^{-1}$
Effective Moving Mass	M_{MS}		gms
Mechanical Resistance	R_{MS}		$\text{N} \cdot \text{s} \cdot \text{m}^{-1}$
Voice Coil Diameter	-		mm
Voice Coil Length	-		mm
Voice Coil Nominal Resistance	-		Ohms
Voice Coil Nominal Impedance	-		Ohms
Voice Coil Maximum Travel Peak to Peak	-		mm
Magnet Total Flux	Φ		$\times 10^{-3} \text{Wb}$
Magnet Flux Density	B		Tesla
Magnet B-I product	$B \cdot I$		$\text{N} \cdot \text{A}^{-1}$
Magnet Gap Length	-		mm
Magnet Gap Volume	-		$\times 10^{-6} \text{m}^3$
Diaphragm Effective Area	S_D		cm^2
<i>Mechanical Specifications</i>			
Surround Type	-		-
Overall Diameter	A		mm
Baffle Hole Diameter	B		mm
Magnet Diameter	C		mm
Front Mount Rebate Depth	D		mm
Overall Depth	E		mm
Mounting Hole Size	F		-
Mounting Hole P.C.D.	G		mm
Shipping Weight	-		kg
Pack Size	-		cm

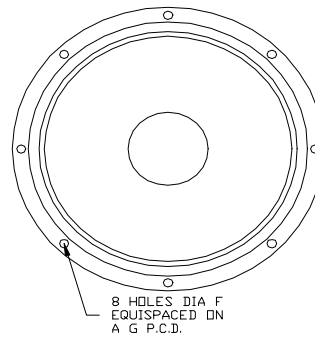
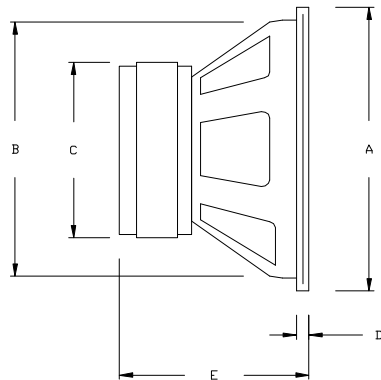
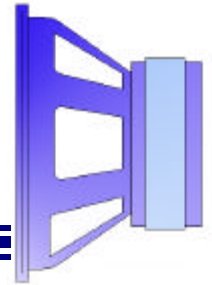

<i>Electroacoustic Specifications</i>	<i>Symbol</i>	<i>Value</i>	<i>Units</i>
Sensitivity	-	83	dB SPL
Normal Power Rating	-		Watts
Maximum Input Power	-		Watts
Maximum Programme Power	-		Watts
Usable Frequency Range	-		Hz
Recommended Crossover Frequencies	-		Hz
Nominal Free Air Resonance	f_s	38	Hz
Mechanical Damping	Q_{MS}	7.6	-
Electromagnetic Damping	Q_{ES}	0.8	-
Total Damping	Q_{TS}	0.7252841	-
		4	
Equivalent Compliance Volume	V_{AS}	10	Litres
Suspension Compliance	C_{MS}	10.1	$\times 10^{-4} \text{m} \cdot \text{N}^{-1}$
Effective Moving Mass	M_{MS}	17	gms
Mechanical Resistance	R_{MS}	1	$\text{N} \cdot \text{s} \cdot \text{m}^{-1}$
Voice Coil Diameter	-	45	mm
Voice Coil Length	-		mm
Voice Coil Nominal Resistance	-		Ohms
Voice Coil Nominal Impedance	-	8	Ohms
Voice Coil Maximum Travel Peak to Peak	-		mm
Magnet Total Flux	Φ		$\times 10^{-3} \text{Wb}$
Magnet Flux Density	B		Tesla
Magnet B-I product	$B \cdot l$	6	$\text{N} \cdot \text{A}^{-1}$
Magnet Gap Length	-	15	mm
Magnet Gap Volume	-	0.00	$\times 10^{-6} \text{m}^3$
Diaphragm Effective Area	S_D		cm^2
<i>Mechanical Specifications</i>			
Surround Type	-	Rubber	-
Overall Diameter	A		mm
Baffle Hole Diameter	B		mm
Magnet Diameter	C		mm
Front Mount Rebate Depth	D		mm
Overall Depth	E		mm
Mounting Hole Size	F		-
Mounting Hole P.C.D.	G		mm
Shipping Weight	-	5..25	kg
Pack Size	-	36x36x22	cm

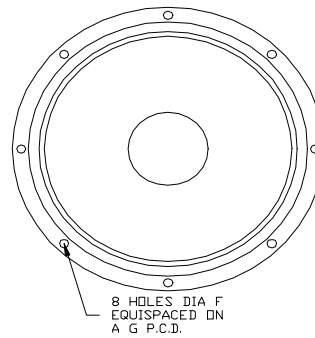
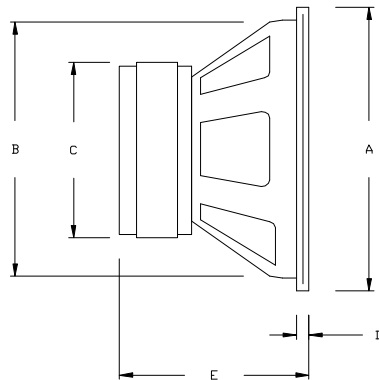
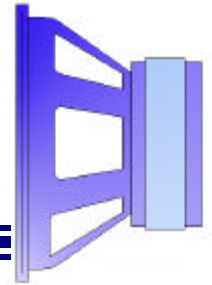

<i>Electroacoustic Specifications</i>	<i>Symbol</i>	<i>Value</i>	<i>Units</i>
Sensitivity	-	85	dB SPL
Normal Power Rating	-		Watts
Maximum Input Power	-		Watts
Maximum Programme Power	-		Watts
Usable Frequency Range	-		Hz
Recommended Crossover Frequencies	-		Hz
Nominal Free Air Resonance	f_s	57	Hz
Mechanical Damping	Q_{MS}	7.6	-
Electromagnetic Damping	Q_{ES}	0.9	-
Total Damping	Q_{TS}	0.8431481	-
Equivalent Compliance Volume	V_{AS}	7	Litres
Suspension Compliance	C_{MS}	1.8	$\times 10^{-4} \text{m} \cdot \text{N}^{-1}$
Effective Moving Mass	M_{MS}	43	gms
Mechanical Resistance	R_{MS}	2	$\text{N} \cdot \text{s} \cdot \text{m}^{-1}$
Voice Coil Diameter	-	75	mm
Voice Coil Length	-		mm
Voice Coil Nominal Resistance	-		Ohms
Voice Coil Nominal Impedance	-	8	Ohms
Voice Coil Maximum Travel Peak to Peak	-		mm
Magnet Total Flux	Φ		$\times 10^{-3} \text{Wb}$
Magnet Flux Density	B		Tesla
Magnet B-I product	$B \cdot I$	8	$\text{N} \cdot \text{A}^{-1}$
Magnet Gap Length	-		mm
Magnet Gap Volume	-	0.00	$\times 10^{-6} \text{m}^3$
Diaphragm Effective Area	S_D		cm^2
<i>Mechanical Specifications</i>			
Surround Type	-	Rubber	-
Overall Diameter	A		mm
Baffle Hole Diameter	B		mm
Magnet Diameter	C		mm
Front Mount Rebate Depth	D		mm
Overall Depth	E		mm
Mounting Hole Size	F		-
Mounting Hole P.C.D.	G		mm
Shipping Weight	-	10.68	kg
Pack Size	-	36x36x22	cm

SB45-125 LONG COIL

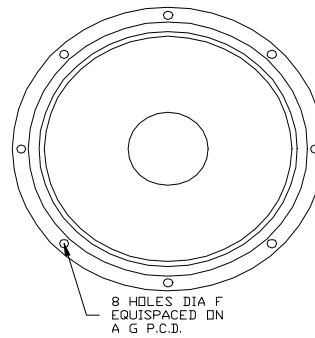
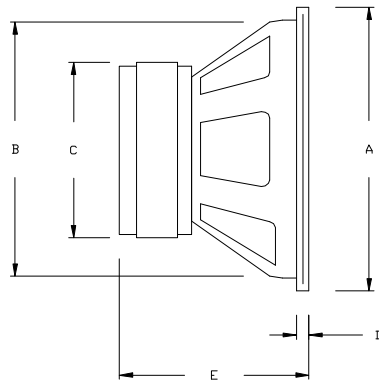
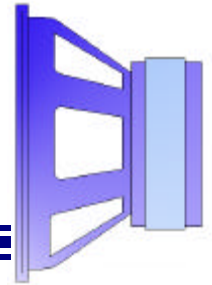

<i>Electroacoustic Specifications</i>	<i>Symbol</i>	<i>Value</i>	<i>Units</i>
Sensitivity	-	84	dB SPL
Normal Power Rating	-		Watts
Maximum Input Power	-		Watts
Maximum Programme Power	-		Watts
Usable Frequency Range	-		Hz
Recommended Crossover Frequencies	-		Hz
Nominal Free Air Resonance	f_s	48	Hz
Mechanical Damping	Q_{MS}	8.4	-
Electromagnetic Damping	Q_{ES}	0.7	-
Total Damping	Q_{TS}	0.6285228	-
		7	
Equivalent Compliance Volume	V_{AS}	6	Litres
Suspension Compliance	C_{MS}	6.2	$\times 10^{-4} \text{m} \cdot \text{N}^{-1}$
Effective Moving Mass	M_{MS}	18	gms
Mechanical Resistance	R_{MS}	1	$\text{N} \cdot \text{s} \cdot \text{m}^{-1}$
Voice Coil Diameter	-	45	mm
Voice Coil Length	-		mm
Voice Coil Nominal Resistance	-		Ohms
Voice Coil Nominal Impedance	-	8	Ohms
Voice Coil Maximum Travel Peak to Peak	-		mm
Magnet Total Flux	Φ		$\times 10^{-3} \text{Wb}$
Magnet Flux Density	B		Tesla
Magnet B-I product	$B \cdot l$	7	$\text{N} \cdot \text{A}^{-1}$
Magnet Gap Length	-		mm
Magnet Gap Volume	-	0.00	$\times 10^{-6} \text{m}^3$
Diaphragm Effective Area	S_D		cm^2
<i>Mechanical Specifications</i>			
Surround Type	-	Rubber	-
Overall Diameter	A		mm
Baffle Hole Diameter	B		mm
Magnet Diameter	C		mm
Front Mount Rebate Depth	D		mm
Overall Depth	E		mm
Mounting Hole Size	F		-
Mounting Hole P.C.D.	G		mm
Shipping Weight	-	5.25	kg
Pack Size	-	36x36x22	cm

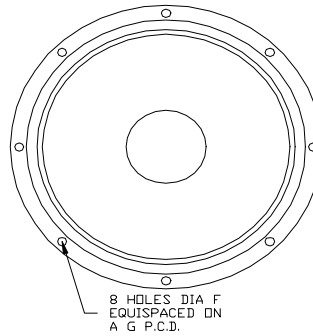
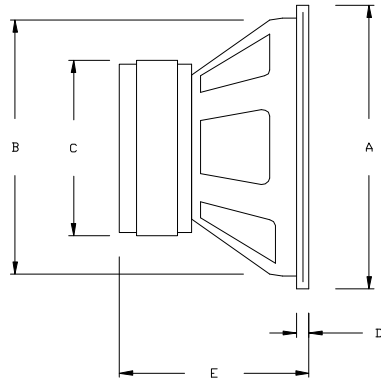

<i>Electroacoustic Specifications</i>	<i>Symbol</i>	<i>Value</i>	<i>Units</i>
Sensitivity	-		dB SPL
Normal Power Rating	-		Watts
Maximum Input Power	-		Watts
Maximum Programme Power	-		Watts
Usable Frequency Range	-		Hz
Recommended Crossover Frequencies	-		Hz
Nominal Free Air Resonance	f_s		Hz
Mechanical Damping	Q_{MS}		-
Electromagnetic Damping	Q_{ES}		-
Total Damping	Q_{TS}		-
Equivalent Compliance Volume	V_{AS}		Litres
Suspension Compliance	C_{MS}		$\times 10^{-4} \text{m} \cdot \text{N}^{-1}$
Effective Moving Mass	M_{MS}		gms
Mechanical Resistance	R_{MS}		$\text{N} \cdot \text{s} \cdot \text{m}^{-1}$
Voice Coil Diameter	-	75	mm
Voice Coil Length	-		mm
Voice Coil Nominal Resistance	-		Ohms
Voice Coil Nominal Impedance	-	4	Ohms
Voice Coil Maximum Travel Peak to Peak	-		mm
Magnet Total Flux	Φ		$\times 10^{-3} \text{Wb}$
Magnet Flux Density	B		Tesla
Magnet B-I product	$B \cdot I$		$\text{N} \cdot \text{A}^{-1}$
Magnet Gap Length	-		mm
Magnet Gap Volume	-	0.00	$\times 10^{-6} \text{m}^3$
Diaphragm Effective Area	S_D		cm^2
<i>Mechanical Specifications</i>			
Surround Type	-		-
Overall Diameter	A		mm
Baffle Hole Diameter	B		mm
Magnet Diameter	C		mm
Front Mount Rebate Depth	D		mm
Overall Depth	E		mm
Mounting Hole Size	F		-
Mounting Hole P.C.D.	G		mm
Shipping Weight	-	7.04	kg
Pack Size	-	36x36x22	cm

SM75-150 8 OHM

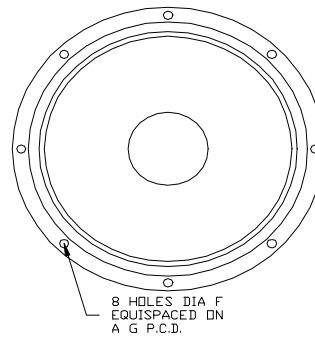
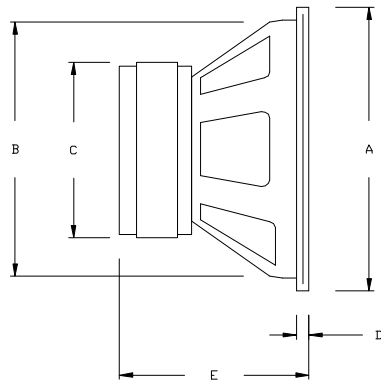
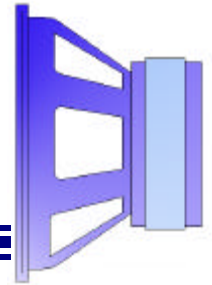

<i>Electroacoustic Specifications</i>	<i>Symbol</i>	<i>Value</i>	<i>Units</i>
Sensitivity	-		dB SPL
Normal Power Rating	-		Watts
Maximum Input Power	-		Watts
Maximum Programme Power	-		Watts
Usable Frequency Range	-		Hz
Recommended Crossover Frequencies	-		Hz
Nominal Free Air Resonance	f_s		Hz
Mechanical Damping	Q_{MS}		-
Electromagnetic Damping	Q_{ES}		-
Total Damping	Q_{TS}		-
Equivalent Compliance Volume	V_{AS}		Litres
Suspension Compliance	C_{MS}		$\times 10^{-4} \text{m} \cdot \text{N}^{-1}$
Effective Moving Mass	M_{MS}		gms
Mechanical Resistance	R_{MS}		$\text{N} \cdot \text{s} \cdot \text{m}^{-1}$
Voice Coil Diameter	-	75	mm
Voice Coil Length	-		mm
Voice Coil Nominal Resistance	-		Ohms
Voice Coil Nominal Impedance	-	8	Ohms
Voice Coil Maximum Travel Peak to Peak	-		mm
Magnet Total Flux	Φ		$\times 10^{-3} \text{Wb}$
Magnet Flux Density	B		Tesla
Magnet B-I product	$B \cdot I$		$\text{N} \cdot \text{A}^{-1}$
Magnet Gap Length	-		mm
Magnet Gap Volume	-	0.00	$\times 10^{-6} \text{m}^3$
Diaphragm Effective Area	S_D		cm^2
<i>Mechanical Specifications</i>			
Surround Type	-		-
Overall Diameter	A		mm
Baffle Hole Diameter	B		mm
Magnet Diameter	C		mm
Front Mount Rebate Depth	D		mm
Overall Depth	E		mm
Mounting Hole Size	F		-
Mounting Hole P.C.D.	G		mm
Shipping Weight	-	7.04	kg
Pack Size	-	36x36x22	cm

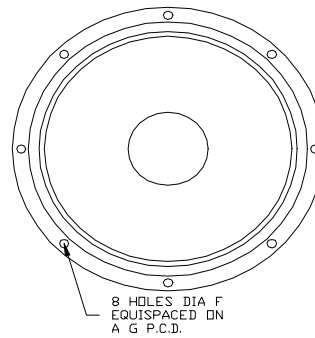
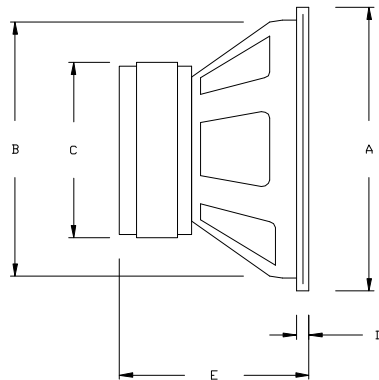
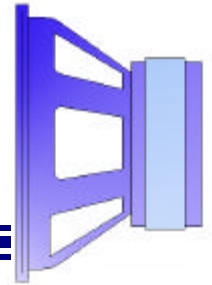

<i>Electroacoustic Specifications</i>	<i>Symbol</i>	<i>Value</i>	<i>Units</i>
Sensitivity	-		dB SPL
Normal Power Rating	-		Watts
Maximum Input Power	-		Watts
Maximum Programme Power	-		Watts
Usable Frequency Range	-		Hz
Recommended Crossover Frequencies	-		Hz
Nominal Free Air Resonance	f_s		Hz
Mechanical Damping	Q_{MS}		-
Electromagnetic Damping	Q_{ES}		-
Total Damping	Q_{TS}		-
Equivalent Compliance Volume	V_{AS}		Litres
Suspension Compliance	C_{MS}		$\times 10^{-4} \text{m} \cdot \text{N}^{-1}$
Effective Moving Mass	M_{MS}		gms
Mechanical Resistance	R_{MS}		$\text{N} \cdot \text{s} \cdot \text{m}^{-1}$
Voice Coil Diameter	-	75	mm
Voice Coil Length	-		mm
Voice Coil Nominal Resistance	-		Ohms
Voice Coil Nominal Impedance	-	16	Ohms
Voice Coil Maximum Travel Peak to Peak	-		mm
Magnet Total Flux	Φ		$\times 10^{-3} \text{Wb}$
Magnet Flux Density	B		Tesla
Magnet B-I product	$B \cdot I$		$\text{N} \cdot \text{A}^{-1}$
Magnet Gap Length	-		mm
Magnet Gap Volume	-	0.00	$\times 10^{-6} \text{m}^3$
Diaphragm Effective Area	S_D		cm^2
<i>Mechanical Specifications</i>			
Surround Type	-		-
Overall Diameter	A		mm
Baffle Hole Diameter	B		mm
Magnet Diameter	C		mm
Front Mount Rebate Depth	D		mm
Overall Depth	E		mm
Mounting Hole Size	F		-
Mounting Hole P.C.D.	G		mm
Shipping Weight	-	7.04	kg
Pack Size	-	36x36x22	cm

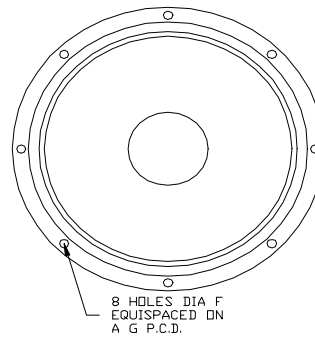
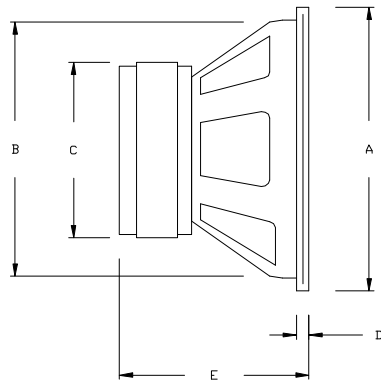
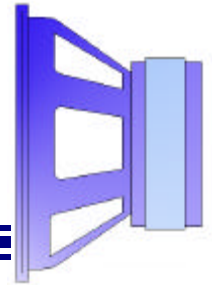

<i>Electroacoustic Specifications</i>	<i>Symbol</i>	<i>Value</i>	<i>Units</i>
Sensitivity	-		dB SPL
Normal Power Rating	-		Watts
Maximum Input Power	-		Watts
Maximum Programme Power	-		Watts
Usable Frequency Range	-		Hz
Recommended Crossover Frequencies	-		Hz
Nominal Free Air Resonance	f_s		Hz
Mechanical Damping	Q_{MS}		-
Electromagnetic Damping	Q_{ES}		-
Total Damping	Q_{TS}		-
Equivalent Compliance Volume	V_{AS}		Litres
Suspension Compliance	C_{MS}		$\times 10^{-4} \text{m} \cdot \text{N}^{-1}$
Effective Moving Mass	M_{MS}		gms
Mechanical Resistance	R_{MS}		$\text{N} \cdot \text{s} \cdot \text{m}^{-1}$
Voice Coil Diameter	-	75	mm
Voice Coil Length	-		mm
Voice Coil Nominal Resistance	-		Ohms
Voice Coil Nominal Impedance	-	4	Ohms
Voice Coil Maximum Travel Peak to Peak	-		mm
Magnet Total Flux	Φ		$\times 10^{-3} \text{Wb}$
Magnet Flux Density	B		Tesla
Magnet B-I product	$B \cdot I$		$\text{N} \cdot \text{A}^{-1}$
Magnet Gap Length	-		mm
Magnet Gap Volume	-	0.00	$\times 10^{-6} \text{m}^3$
Diaphragm Effective Area	S_D		cm^2
<i>Mechanical Specifications</i>			
Surround Type	-		-
Overall Diameter	A		mm
Baffle Hole Diameter	B		mm
Magnet Diameter	C		mm
Front Mount Rebate Depth	D		mm
Overall Depth	E		mm
Mounting Hole Size	F		-
Mounting Hole P.C.D.	G		mm
Shipping Weight	-	9.09	kg
Pack Size	-	36x36x22	cm

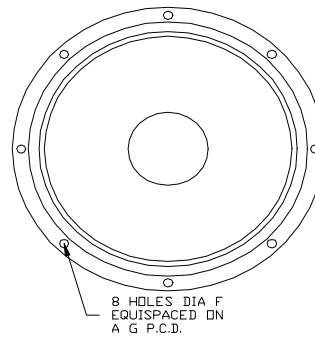
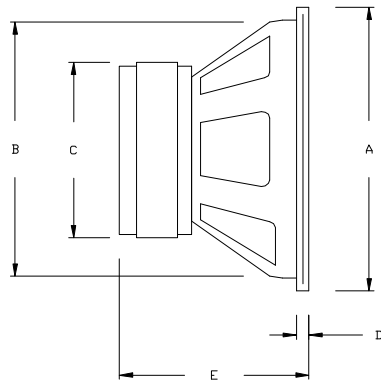
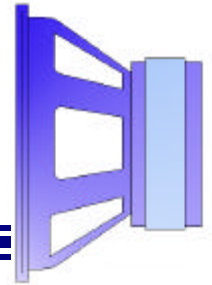

<i>Electroacoustic Specifications</i>	<i>Symbol</i>	<i>Value</i>	<i>Units</i>
Sensitivity	-		dB SPL
Normal Power Rating	-		Watts
Maximum Input Power	-		Watts
Maximum Programme Power	-		Watts
Usable Frequency Range	-		Hz
Recommended Crossover Frequencies	-		Hz
Nominal Free Air Resonance	f_s		Hz
Mechanical Damping	Q_{MS}		-
Electromagnetic Damping	Q_{ES}		-
Total Damping	Q_{TS}		-
Equivalent Compliance Volume	V_{AS}		Litres
Suspension Compliance	C_{MS}		$\times 10^{-4} \text{m} \cdot \text{N}^{-1}$
Effective Moving Mass	M_{MS}		gms
Mechanical Resistance	R_{MS}		$\text{N} \cdot \text{s} \cdot \text{m}^{-1}$
Voice Coil Diameter	-	75	mm
Voice Coil Length	-		mm
Voice Coil Nominal Resistance	-		Ohms
Voice Coil Nominal Impedance	-	8	Ohms
Voice Coil Maximum Travel Peak to Peak	-		mm
Magnet Total Flux	Φ		$\times 10^{-3} \text{Wb}$
Magnet Flux Density	B		Tesla
Magnet B-I product	$B \cdot I$		$\text{N} \cdot \text{A}^{-1}$
Magnet Gap Length	-		mm
Magnet Gap Volume	-	0.00	$\times 10^{-6} \text{m}^3$
Diaphragm Effective Area	S_D		cm^2
<i>Mechanical Specifications</i>			
Surround Type	-		-
Overall Diameter	A		mm
Baffle Hole Diameter	B		mm
Magnet Diameter	C		mm
Front Mount Rebate Depth	D		mm
Overall Depth	E		mm
Mounting Hole Size	F		-
Mounting Hole P.C.D.	G		mm
Shipping Weight	-	9.09	kg
Pack Size	-	36x36x22	cm

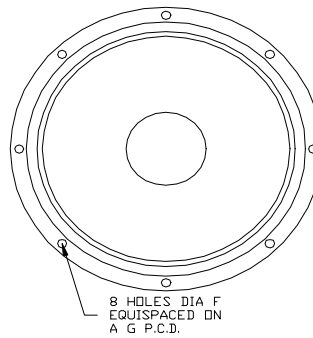
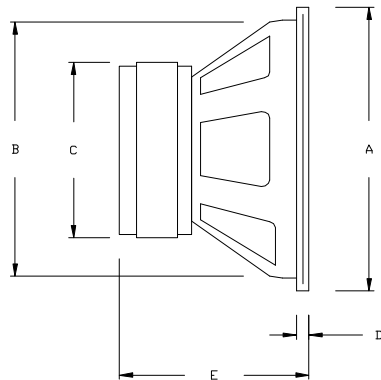
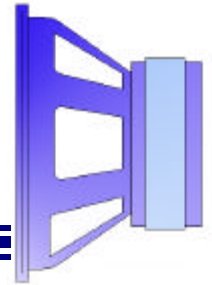

<i>Electroacoustic Specifications</i>	<i>Symbol</i>	<i>Value</i>	<i>Units</i>
Sensitivity	-		dB SPL
Normal Power Rating	-		Watts
Maximum Input Power	-		Watts
Maximum Programme Power	-		Watts
Usable Frequency Range	-		Hz
Recommended Crossover Frequencies	-		Hz
Nominal Free Air Resonance	f_s		Hz
Mechanical Damping	Q_{MS}		-
Electromagnetic Damping	Q_{ES}		-
Total Damping	Q_{TS}		-
Equivalent Compliance Volume	V_{AS}		Litres
Suspension Compliance	C_{MS}		$\times 10^{-4} \text{m} \cdot \text{N}^{-1}$
Effective Moving Mass	M_{MS}		gms
Mechanical Resistance	R_{MS}		$\text{N} \cdot \text{s} \cdot \text{m}^{-1}$
Voice Coil Diameter	-	75	mm
Voice Coil Length	-		mm
Voice Coil Nominal Resistance	-		Ohms
Voice Coil Nominal Impedance	-	16	Ohms
Voice Coil Maximum Travel Peak to Peak	-		mm
Magnet Total Flux	Φ		$\times 10^{-3} \text{Wb}$
Magnet Flux Density	B		Tesla
Magnet B-I product	B-I		$\text{N} \cdot \text{A}^{-1}$
Magnet Gap Length	-		mm
Magnet Gap Volume	-	0.00	$\times 10^{-6} \text{m}^3$
Diaphragm Effective Area	S_D		cm^2
<i>Mechanical Specifications</i>			
Surround Type	-		-
Overall Diameter	A		mm
Baffle Hole Diameter	B		mm
Magnet Diameter	C		mm
Front Mount Rebate Depth	D		mm
Overall Depth	E		mm
Mounting Hole Size	F		-
Mounting Hole P.C.D.	G		mm
Shipping Weight	-	9.09	kg
Pack Size	-	36x36x22	cm