

High-performance studio surface monitor

SSM12i Pro
SSM25i Pro

MANUAL

Made in England by ATC

PRO SERIES

ACOUSTIC
ENGINEERS

ATC

Important: Before installation, Section 6.0 in this document must be read in its entirety.

- 1 **Read Instructions:** All safety and operating instructions must be read prior to using the appliance.
- 2 **Retain Instructions:** Keep this manual for future reference.
- 3 **Follow Instructions:** Adhere strictly to all operating and installation guidelines.
- 4 **Water and Moisture:**
Do not expose the appliance to dripping or splashing liquids.
Avoid placing objects containing liquids, such as vases, on the appliance.
- 5 **Heat:** Keep the appliance away from heat sources, such as radiators, stoves, or other devices that generate heat.
- 6 **Cleaning:** Clean the appliance only as recommended in this manual.
- 7 **Servicing:** Users should not attempt to service the appliance beyond the procedures outlined in the operating instructions. Any additional servicing must be performed by qualified service personnel.
- 8 **Mounting:** Installation, fitting, mounting, suspension, connection or commissioning of any loudspeaker should be carried out by an experienced professional. Improperly installed loudspeakers can result in damage, injury or harm which is the sole liability of the Customer or installing contractor. Loudspeaker Technology Limited is not liable for any damage, injury or harm arising from improper installation.



SECTION ONE

- 1.0 Welcome

SECTION TWO

- Product Description*
- 2.0 SSM (Studio Surface Monitor) Range
 - 2.1 SSM12i Pro
 - 2.2 SSM25i Pro

SECTION THREE

- 3.0 Room Interaction

SECTION FOUR

- 4.0 Unpacking and Handling

SECTION FIVE

- 5.0 Monitor Placement

SECTION SIX

- 6.0 Bracket Assembly, and Loudspeaker Mounting
- 6.1 Bracket Assembly and Installation Steps
- 6.2 Driver Reconfiguration

SECTION SEVEN

- 7.0 Connection

SECTION EIGHT

- 8.0 Amplification

SECTION NINE

- Specifications*
- 9.0 SSM12i Pro Acoustic Specifications
 - 9.1 SSM12i Pro Physical Specifications
 - 9.2 SSM25i Pro Acoustic Specifications
 - 9.3 SSM25i Pro Physical Specifications

SECTION TEN

- 10.1 Care & Maintenance
- 10.2 Warranty
- 10.3 Contact

10 Welcome

In selecting ATC you have chosen an example of the finest audio engineering available. ATC was founded on a principle of engineering excellence, and that principle still defines our products today. Given the right opportunities, ATC products will deliver exceptional audio performance, but the opportunities will only arise from careful and thoughtful installation and use. Please read the following manual fully. It will help you understand the product and to realise its full potential. If you need further assistance, please contact your local ATC representative. ATC contact details can be found at the rear of this manual.

ATC was founded in London in 1974 by Australian emigre Billy Woodman. An enthusiastic pianist and engineer he was naturally drawn to loudspeaker design and after a period working at Goodmans, where many of the names that went on to found British loudspeaker companies began their careers, he struck out on his own. The premise on which ATC began is a simple one, and one that in many respects is still true today: Hi-Fi loudspeakers tend to be detailed and accurate but of limited dynamic range, while professional monitor speakers tend to express the opposite character: ATC products were designed from the outset to offer the best of both. It's an easy concept to describe, but surprisingly difficult to engineer.

The difficulty inherent in designing such loudspeakers is one of scale. Hi-Fi levels of accuracy and detail call for lightweight moving parts and delicate engineering. Professional monitor levels of performance however demand far more robust components engineered to survive the rigours of high-level use for extended periods. The only way to combine the two is through precision engineering of a class and scale more often associated with aerospace or motor sport. But the results are worth the effort and the cost. ATC loudspeakers, with their unique in-house designed drivers, combine the best of hi-fi and professional to devastating effect.

From modest beginnings ATC has grown to become one of the very few manufacturers successful across both domestic and professional audio. By selecting ATC you join a group of music lovers, professional audio engineers, studios and musicians across the world that understand and value the engineering that goes into an ATC product – and the sound that comes out.





2.0 **SSM (Studio Surface Monitor) Range**

The SSM range of loudspeakers is engineered to deliver exceptional performance when mounted on control room walls and ceilings. Featuring a versatile mounting bracket solution, these loudspeakers offer flexible installation options, making them an ideal choice for multichannel and immersive audio setups, including Dolby Atmos systems. Their shallow depth makes them particularly well suited to compact control rooms where space is at a premium.

2.1 **SSM12i Pro**

The SSM12i Pro is a compact, high-performance passive 2-way loudspeaker built around proprietary drive units designed and manufactured by ATC. Operating in a sealed cabinet, at low and mid-range frequencies, the ATC SB45-150CLD bass/mid driver is employed. This advanced driver features a unique constrained layer damping (CLD) cone, which effectively minimises cone breakup—a common issue in 2-way loudspeakers. The sealed cabinet design and custom crossover network are engineered to deliver optimal performance when the loudspeaker is mounted on/close to a hard wall/surface.

For frequencies above the 2.2kHz crossover point, ATC's innovative SH25-76 dual-suspension tweeter ensures precise and transparent reproduction of high-frequency content. Together, these advanced components provide the SSM12i Pro with outstanding clarity, balance, and detail, making it a superior choice for demanding audio environments.

The SSM12i Pro is supplied in pairs, either in Portrait orientation or Landscape orientation. Mixed orientations (e.g., one Portrait and one Landscape) are not available. However, if needed, the tweeter position can be adjusted on site, see Section 6.2.

2.2 **SSM25i Pro**

The SSM25i Pro is a mid-sized, high-performance passive 3-way loudspeaker that delivers exceptional audio quality through a combination of advanced engineering and premium components. It features three proprietary ATC drive units housed in a sealed cabinet design for precise and consistent performance.

ATC's SB50-164SC bass driver operates at frequencies up to 380Hz, utilising a short coil/long gap design and paper/carbon fibre cone, this driver provides an extended and precise low-frequency output. Midrange frequencies are handled by ATC's renowned SM75-150 midrange dome, celebrated for delivering unmatched clarity and detail—hallmarks of ATC's design expertise.

High frequencies above 3.5kHz are reproduced by the advanced ATC SH25-76S "S-Spec" tweeter. Like the SH25-76, this 25mm soft dome tweeter incorporates a dual suspension design for enhanced mechanical stability, allowing the coil to operate within a tightly toleranced air-cooled magnetic gap. Its superior motor assembly generates a potent 2.0T magnetic field density, resulting in increased efficiency, extended frequency response, and extremely low odd-harmonic distortion.

The seamless integration of these drive units within the sealed cabinet design makes the SSM25i Pro an ideal choice for multichannel and immersive audio applications in medium to large recording studios, including those requiring Dolby Atmos or other immersive audio setups. Like the SSM12i Pro, the SSM25i Pro features a custom crossover network, engineered to deliver optimal performance when the loudspeaker is mounted on/close to a hard wall/surface.

The SSM25i Pro is supplied in pairs, either in Portrait orientation or Landscape orientation. Mixed orientations (e.g., one Portrait and one Landscape) are not available. However, if needed, the tweeter position can be adjusted on site, see Section 6.2.

3.0 Room Interaction

The room in which a loudspeaker is placed can be thought of as a filter; altering the acoustic response at the listening position from that of the loudspeaker. The position of the loudspeaker in a room will influence how it interacts with the space and therefore is often critical to achieving the best performance at the listening position.

Speaker positioning is important because at low frequencies the room will have a strong influence due to room modes/resonances. Room modes manifest themselves in an uneven distribution of acoustic energy within the room, which can lead to either too much or too little bass at the listening position. A room with a well-controlled low frequency response (controlled reverb time) will have a far smaller influence on the performance of the loudspeaker and will be less sensitive to positioning. Typically, a combination of resonant membrane traps and porous absorbers are needed to control the low frequency. The resonant membrane traps are effective at treating the low bass, typically below 80Hz and the porous absorbers frequencies above this. Porous absorbers such as those made from foams, fibreglass or rockwool are not effective at absorbing low bass energy without a very large air space between them and the wall behind which reduces usable space within a room.

The SSM range of loudspeakers are specifically designed for direct mounting onto rigid surfaces such as walls or ceilings. This installation method enhances low-frequency (LF) efficiency and extension, and the SSM range of loudspeakers feature crossovers and bass driver alignments optimised to take advantage of the wall-loading effect. However, mounting against a hard surface also positions the loudspeaker optimally to interact with room modes between the mounting wall and the opposite wall. In such cases, proper bass trapping becomes even more crucial to ensure balanced sound performance. Similarly, placing a loudspeaker near a hard surface increases the likelihood of comb filtering artefacts in the response, caused by strong reflections from the surface, these would generally be present in the midrange band of frequencies. These effects can be mitigated by installing acoustically absorptive material near the loudspeaker.

4.0 Unpacking and Handling

The SSM12i Pro and SSM25i Pro are heavy items and should be handled with care. It is recommended to unpack them on the floor or a sturdy, low table with ample open space around the carton, ideally near their final installation location.

Please scan the following QR code for video guidance on how to unpack these loudspeakers – If you do not have access to the video linked above, please follow the steps below:



- 1 Open the carton and remove all loose items, leaving the packing foam in place.
- 2 Up-end the carton so the open end is facing down.
- 3 Lift the carton off the contents (speaker & foam 'end-caps').
- 4 Remove any items located in the ends of the foam end caps.
- 5 Being careful not to touch the front face of the loudspeaker, remove one foam end cap and stand the loudspeaker on the floor.
- 6 Remove the top foam end cap.
- 7 Remove the loudspeaker bag.

5.0 Monitor Placement

The SSM range of loudspeakers are primarily designed for use in Dolby Atmos and multi-channel surround systems. Placement is therefore largely determined by system requirements and room geometry, but the following considerations should always be kept in mind:

Acoustic Axis: Aim the loudspeaker's acoustic axis/centre towards the listening position. For stereo systems, the acoustic axis should point at or slightly behind the listener's head. If the loudspeaker cannot be positioned at ear height, optimal performance will be achieved by remaining within a vertical window of +/- 5 degrees. Examples shown opposite in diagram 2.

Mounting Orientation: When using the provided bracket to mount the loudspeaker at an angle, ensure the tweeter is positioned furthest from the wall or ceiling. This setup minimises the amount of reflected energy from the tweeter that bounces back off nearby rigid surfaces. An example is shown in diagram 1 below.

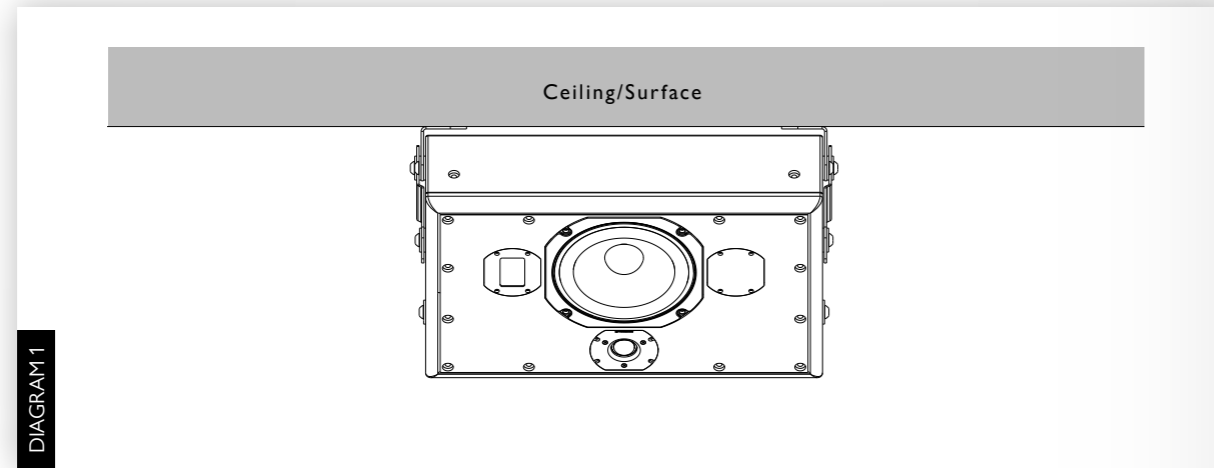
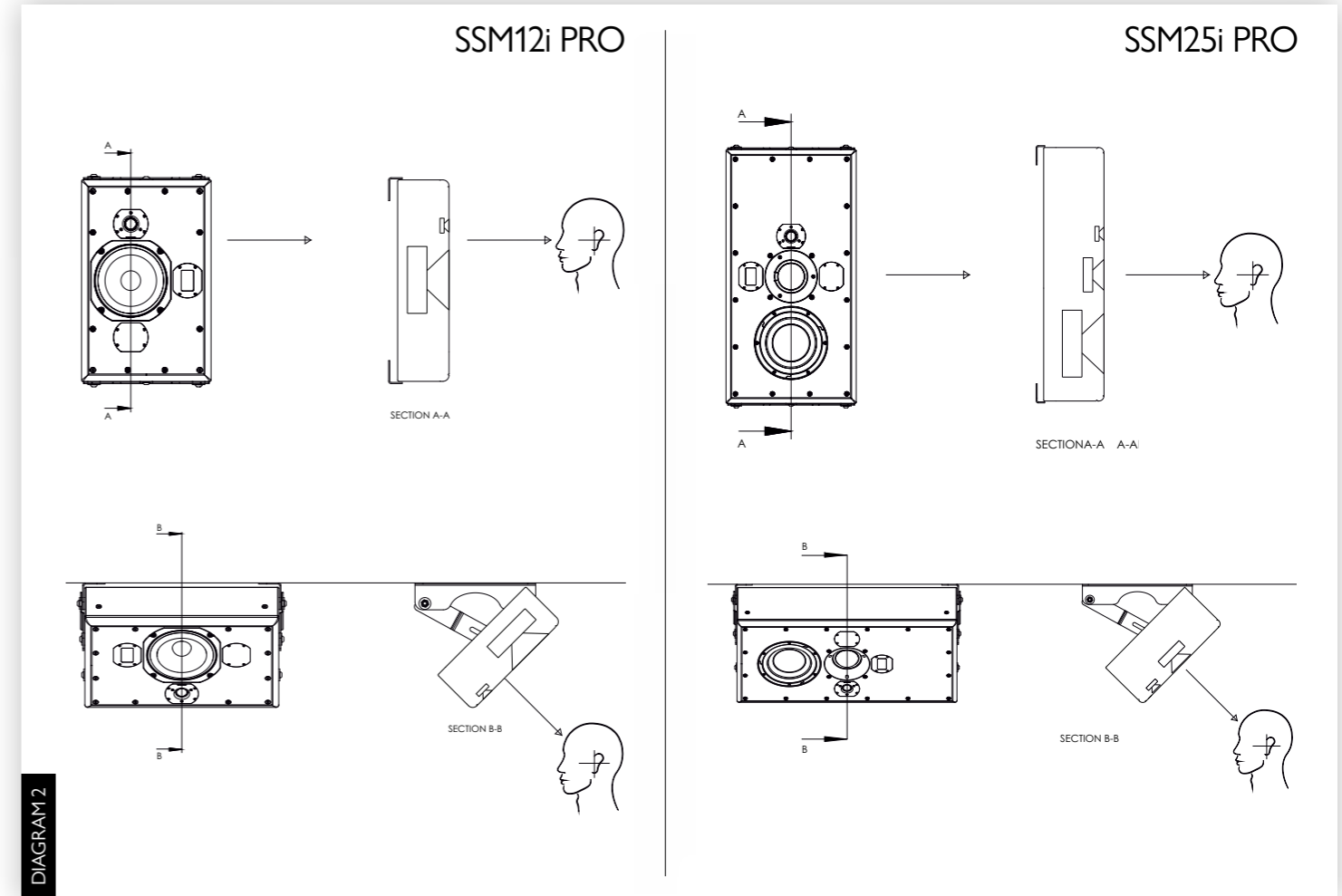

Diagram 1 – SSM12i Pro in a Landscape orientation and showing the tweeter mounted away from the ceiling.

Low-Frequency Balance: The low frequency balance of a loudspeaker is heavily influenced by the room. If the sound is too bass-heavy or too bass-light, experiment with positioning and room treatment before resorting to equalisation.

Equalisation Considerations:

- Cut is Preferred: Use EQ cuts rather than boosts. Boosting EQ reduces the amplifier's headroom and driver excursion capacity.
- Avoid Excessive Boost: Overuse of boost EQ can damage the loudspeaker.
- Room Mode Nulls: Nulls in the frequency response caused by room modes cannot be corrected with EQ.
- Spatial Response Variations: EQ cannot compensate for response differences across various locations in the room.
- Frequency Limitations: EQ adjustments are most effective up to approximately 200Hz, as the area of influence ("EQ space") becomes smaller with increasing frequency.



Position the SSM12i Pro loudspeaker so that the mid-point between mid/bass driver and tweeter is at ear height. Position the SSM25i Pro so the mid-range dome at ear height. If this isn't possible, optimal performance will be achieved by remaining within a vertical window of +/- 5 degrees.

6.0 Bracket Assembly and Loudspeaker Mounting

Important Notice: Professional Installation Required

Installation, fitting, mounting, suspension, connection or commissioning of any loudspeaker should be carried out by an experienced professional. Improperly installed loudspeakers can result in damage, injury or harm which is the sole liability of the Customer or installing contractor. Loudspeaker Technology Limited is not liable for any damage, injury or harm arising from improper installation.

Irrespective of orientation (Portrait or Landscape) the SSM range of loudspeakers can be mounted using the bracket set provided in 2 different ways, "Flat" against a surface or "Angled" with respect to the surface. The angled mounting configuration allows for an adjustment of approximately 15 to 45 degrees with respect to the mounting surface.

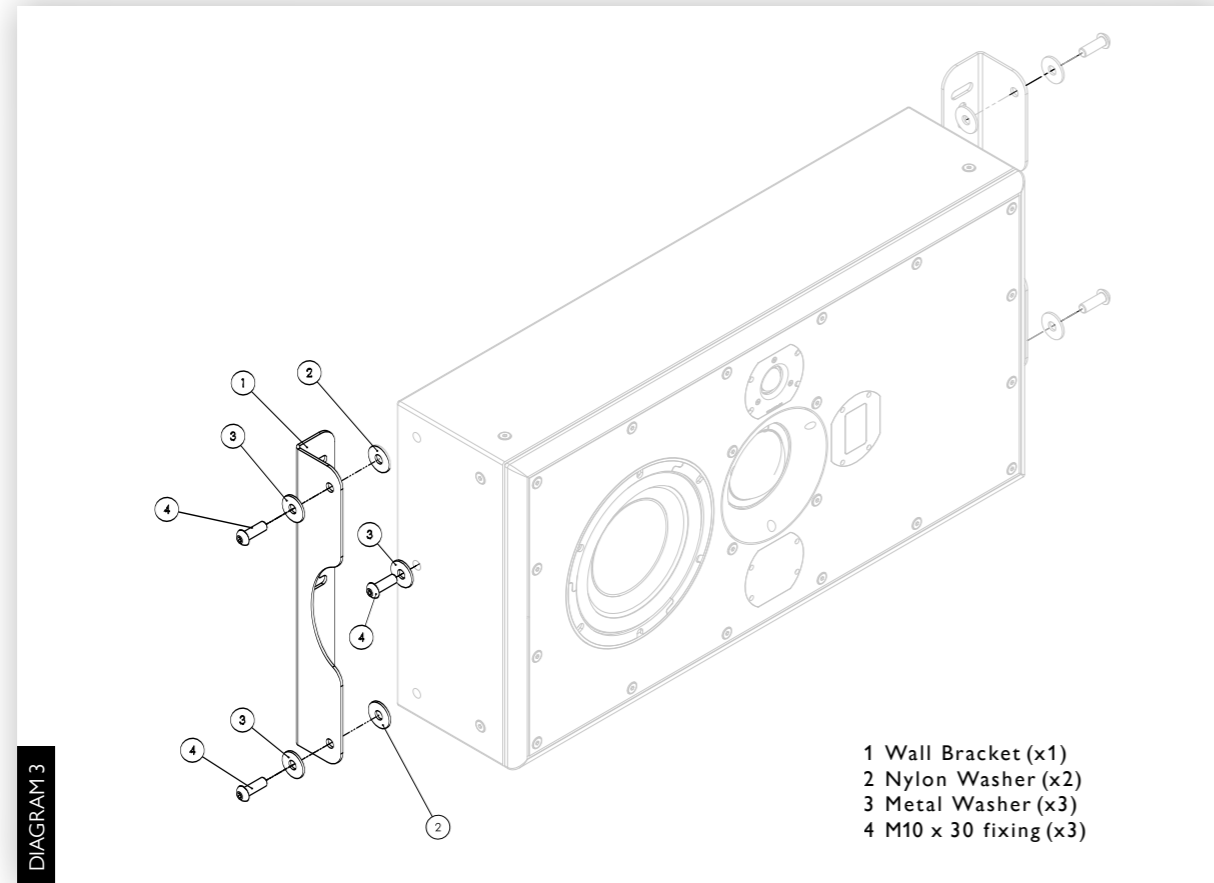

Diagram 3 – Quantities above are for a single bracket and two are required per loudspeaker.

The loudspeaker ships with 6 x cabinet mounting points factory fitted with M10 fixings and metal washers. Additional bracket components and fixings are packed separately in the carton; therefore, assembly is required at the point of installation.

The "Flat" configuration and "Angled" configurations require the bracket be installed in different ways. Please see diagram 3 and diagram 5 showing the final assembly configurations.

Diagram 3 – Final assembly of "Flat" mounting configuration. Note that the bracket must be fixed to the wall before the loudspeaker is attached. See diagram 4 showing the required partial assembly of the bracket.

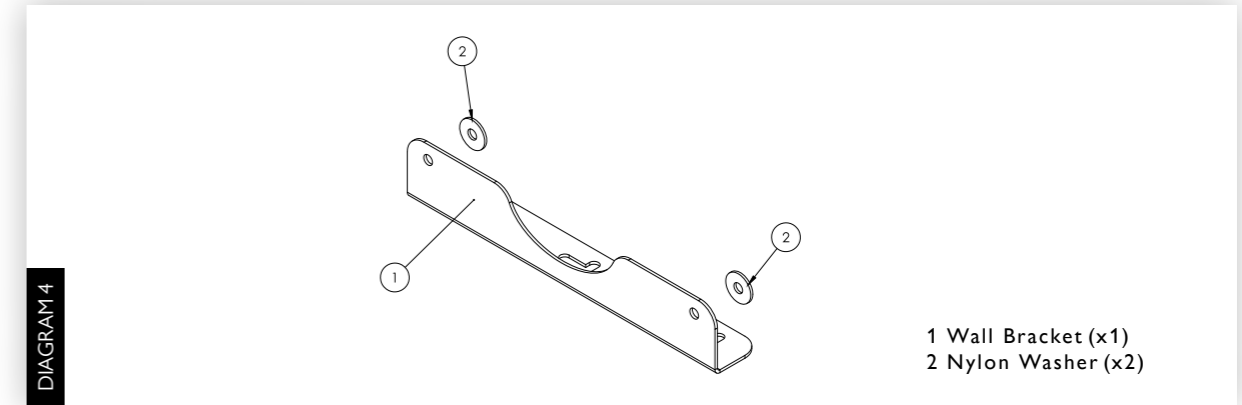

Diagram 4 – Please see the following link for further instructions on assembling the brackets used in the SSM Range.



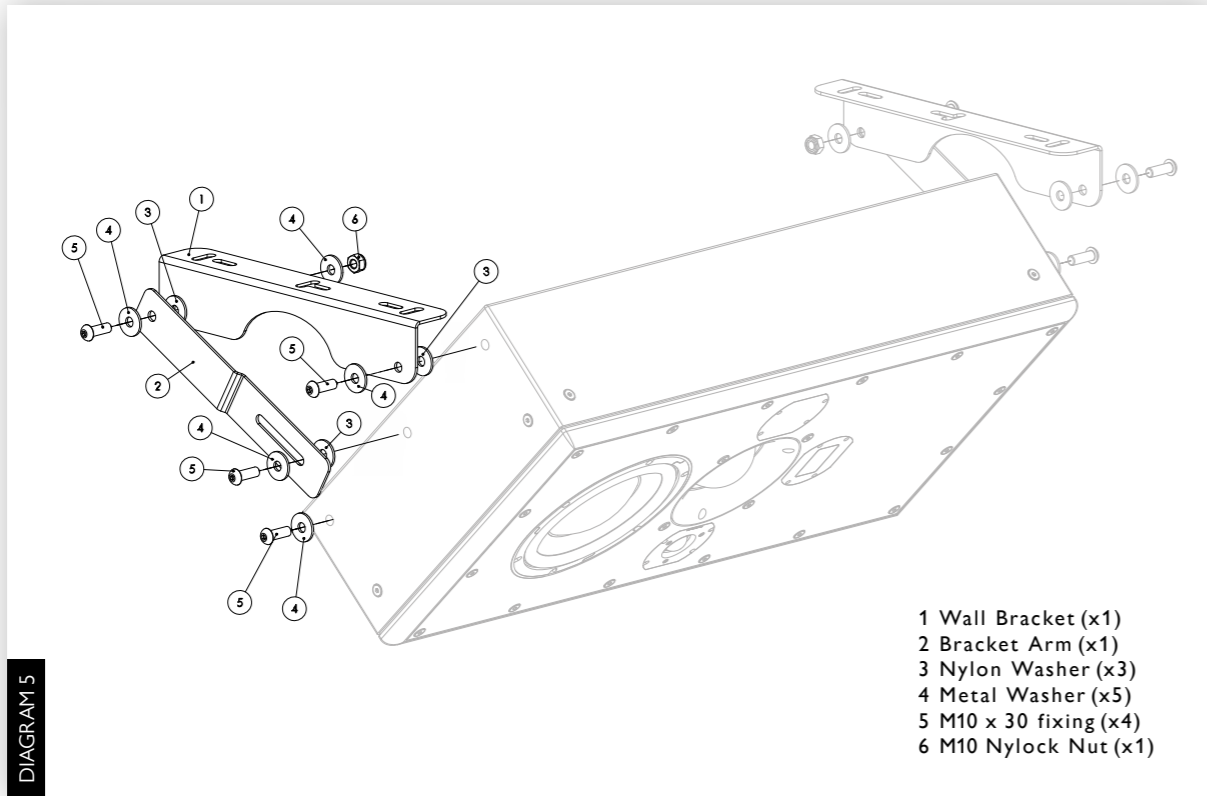

Diagram 5 – Final assembly for “Angled” mounting configuration. Note that the bracket must be fixed to the wall before the loudspeaker is attached. See diagram 6 showing the required partial assembly of the bracket.

Diagram 6 – In the case of an “Angled” mounting configuration, the bracket should be partially assembled as shown before mounting.

Tip – Use the adhesive backing on the Nylon washer to fix the washer on the bracket to ease assembly.

Pay particular attention to the locations of the metal and Nylon washers and the direction of the bend in the bracket arm.

The second bracket should be built as a mirror image.

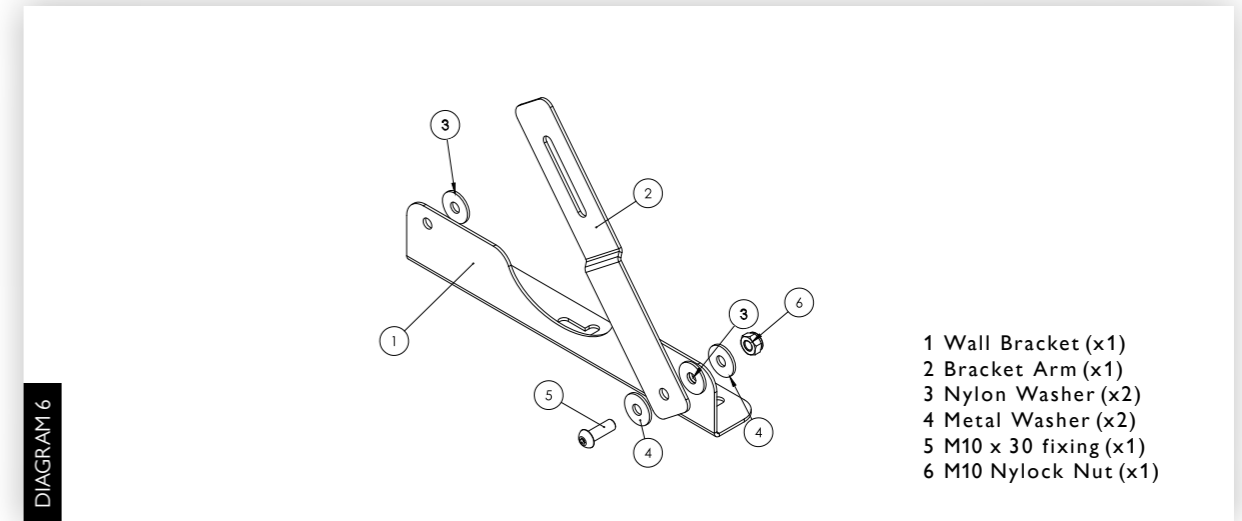

6.1 Bracket Assembly and Installation Steps

Tools required for bracket/loudspeaker assembly: 6.0mm hex driver / 17.0mm socket or spanner

Refer to diagrams 3 and 5 and ensure all components required are present. Follow these steps to mount the loudspeaker properly:

- 1 Determine the Mounting Method**
 - Decide on the desired mounting configuration (e.g., flat or angled).
- 2 Assemble the Bracket**
 - Assemble the Bracket as shown in diagram 4 or 6.
 - Note that the pair of brackets should be constructed as a mirror image pair, only one side is shown in the assembly diagrams.
- 3 Mark and Secure the Wall Bracket**
 - Use the mounting template provided to mark the wall or ceiling.
 - Secure the "Wall Bracket" assembly to the surface, taking care to align it accurately.
 - Note: The slotted holes allow for adjustment in only one direction, so precise fixture placement is critical.
- 4 Fix Nylon Washers**
 - Remove the release paper from the "Nylon Washers," align them perfectly with the holes on the loudspeaker or bracket and fix them in place (refer to diagrams 4 and 6).
- 5 Connect the Audio Cable**
- 6 Mount the Loudspeaker**
 - With assistance, lift the loudspeaker into position.
 - Securely attach the loudspeaker to the bracket.
- 7 Seal Fixing Points**
 - In the case of a "flat" configuration, ensure the remaining/unused M10 fixing points are fitted with a M10 bolt and Metal washer to prevent cabinet air leaks. This is clearly illustrated in diagram 4.
- 8 Attach the Safety Tether – This is a critical requirement in all installations**
 - Secure the safety tether to a suitable anchor point to complete the installation. See diagram 7.

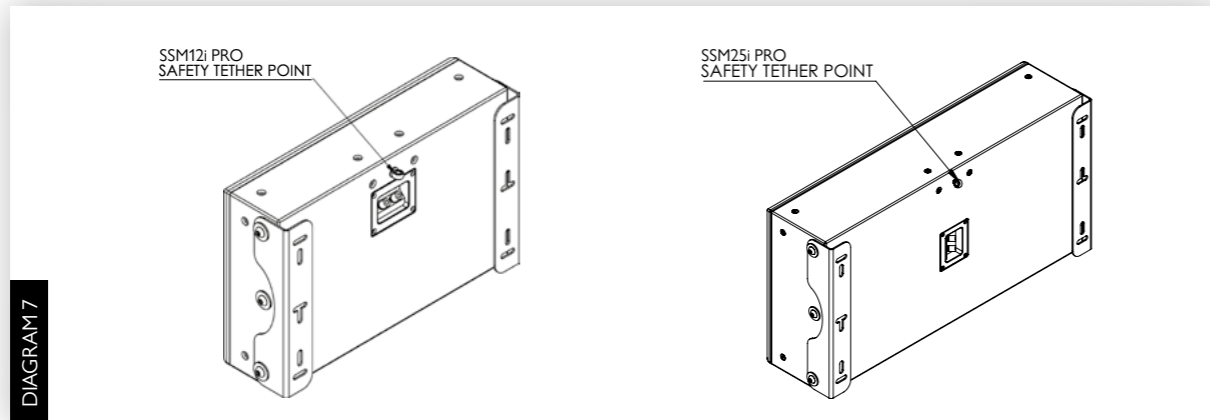

Diagram 7 – The Safety Tether Point is the eyebolt, mounted on the rear of the SSM12i Pro and SSM25i Pro (shown here).

6.2 Driver Reconfiguration

In certain situations, it may be necessary to adjust the SSM loudspeaker configuration by repositioning the tweeter from its factory-set location. Please scan the following QR code for video guidance on how to perform this operation – If you do not have access to the video linked above, please follow the steps below:

Tools required: 2.5mm hex driver / Allen Key or other tool with a shaft smaller than 1.4mm. If you do not have a suitable tool, search online for "Micro Allen Key." A paper clip can also be used.



STEP 1

- 1 Disconnect the loudspeaker.**
- 2 Lay the loudspeaker on its rear face on a sturdy workbench.**
- 3 Place a soft cloth, such as a folded towel or dust cloth, on the baffle near the tweeter. Ensure the cloth does not come into contact with the other drivers.**
- 4 Using a 2.5mm hex driver, unscrew the 4x M3 cap-head fixings holding the tweeter in the baffle.**
- 5 Insert the 2.5mm hex driver shaft into one of the 4 fixing holes and carefully lever against the waveguide to separate the tweeter from the baffle. The tweeter should come free easily. Lift it out gently.**
- 6 Note the wiring connections:**
 - The white wire is connected to the +ve terminal.
 - The yellow wire is connected to the -ve terminal.

Disconnect the audio connection from the tweeter by depressing the small lock/release tab on each spade connector while pulling them apart.
- 7 Place the tweeter on the soft cloth. Be mindful that the magnet on the tweeter is very strong and should be kept away from sensitive electronics, watches etc.**
- 8 Release the yacht wire from the Gripple. Insert a small Allen key into the 1.5mm hole in the Gripple to release the locking mechanism, allowing the yacht wire to come free.**
- 9 Remove the tweeter gasket and set it aside.**

STEP 2 – REMOVE THE TWEETER BLANKING PLATES

- 1 Identify the desired tweeter position and remove the blanking plate. Using a 2.5mm hex driver, unscrew the 4x M3 cap-head fixings holding the blanking plate in the baffle.**
- 2 Remove the blanking plate containing the badge/logo in the same manner.**

STEP 3 – RE-ROUTE INTERNAL WIRING

- 1 Route the internal audio wiring and yacht wire to the desired tweeter position.**
- 2 Fit the tweeter gasket into the rebate.**

STEP 4: RECONNECTION AND ASSEMBLY

- 1 Terminate the yacht wire:** Push the steel yacht wire through the Gripple, route it through the tweeter eyebolt, and back into the Gripple to lock it in place.
- 2 Reconnect the audio wiring:**
 - Connect the white wire to the +ve terminal.
 - Connect the yellow wire to the -ve terminal.
- 3 Carefully place the tweeter back into the baffle and secure it using the 4x M3 cap-head fixings. The ideal fixing torque is 0.6 Nm. If a torque wrench is unavailable, gently tighten the fixings by hand. Rotate each fixing until slight resistance is felt, then tighten an additional half-turn. Do not overtighten.**
- 4 Reposition the plates and secure them with the M3 fixings as described above. The blanking plates are fitted with a neoprene sealing tape on the rear, so no additional gasket is required. Note, the proper position of the logo/badge is on the outside of the pair as shown in the diagrams in section 9 of this manual.**

7.0 Connection

SSM12i Pro and SSM25i Pro monitors are equipped with a single pair of loudspeaker input terminals, mounted in a connection panel on the rear side of the loudspeaker. The terminals can accommodate either stripped bare cable ends, 4mm banana plugs (these may prevent the speaker sitting flush against the wall) or spade terminals. Always use a good quality speaker cable with 2.5mm² minimum cross-sectional area per conductor (79 strand). For cable runs longer than 5 metres use a significantly heavier gauge cable. Consult your dealer or consultant for specific cable recommendations. Ensure that the positive and negative terminals on each connection panel are connected to the corresponding positive and negative terminals on the amplifier. A lack of bass output and very wide unstable stereo image is most likely caused by the left and right loudspeakers being connected out of phase. If the system displays these characteristics, please check the polarity of the wiring.

8.0 Amplification

The choice of partnering amplifier for the monitors will have significant influence on the performance of the system. Consider the following when selecting the amplifier:

- With any passive loudspeaker there is a trade-off between low frequency extension and sensitivity. These monitor's extended low frequency response means the sensitivity is relatively low. It is therefore advisable to select a power amplifier of relatively high-power output capabilities. Typically, best performance comes with use of amplifiers capable of >150W continuous into 8ohms.
- Use of an underpowered amplifier will result in the premature distortion of the system and increased risk of damage due to voice coil overheating.

9.0 SSM12i Pro Acoustic Specifications

Drive Units Bass/Mid: 1 x SB45-150CLD 8Ω
 HF: 1 x SH25-76 6Ω

Low Frequency Cut-off: 56Hz (-6dB, anechoic)

High Frequency Cut-off: 22kHz

Crossover Frequency: 2.2kHz

Recommended Power Amplifier: 75W to 300W

Input Connectors: Binding Posts/4mm Plugs, single pair

MaxSPL: 108dB continuous, 114dB peak, (per pair, IEC weighted Pink Noise, 1m anechoic)

Sensitivity: 85dB/W @1m

Nominal Impedance: 8Ω

Minimum Impedance: 5Ω

9.1 SSM12i Physical Specifications

Net Weight: 14.8kg / 32.6lbs.

Product Dimensions: See diagrams on following pages.

DIAGRAM 8

PORTRAIT ORIENTATION
ANGLED CONFIGURATION A

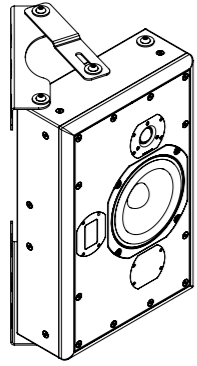

PORTRAIT ORIENTATION
ANGLED CONFIGURATION B

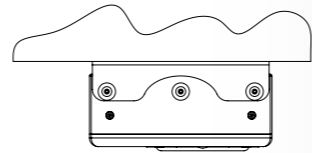
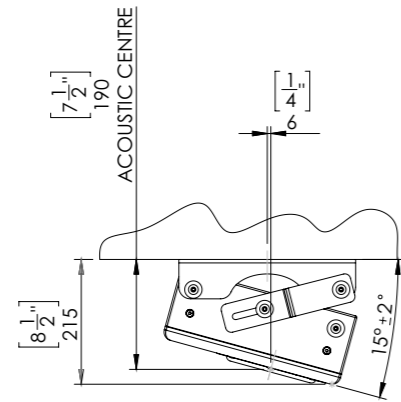
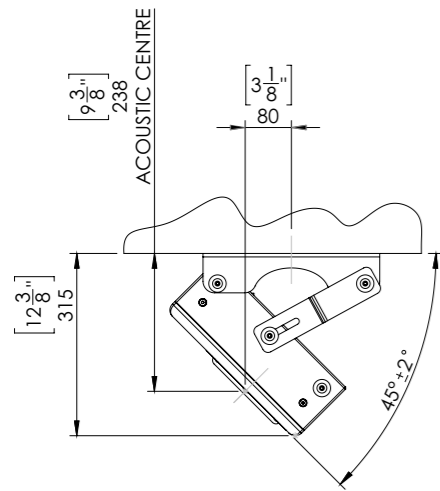
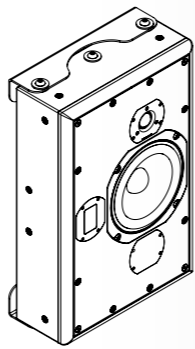
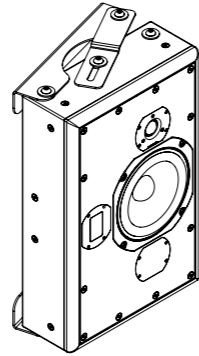
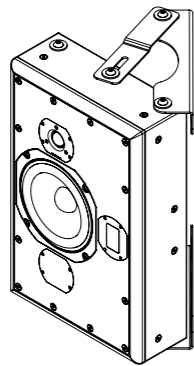
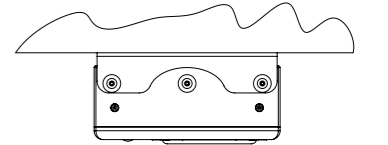
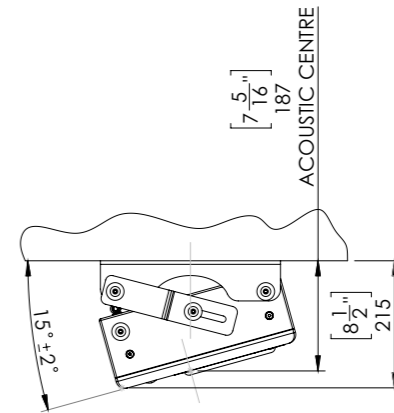
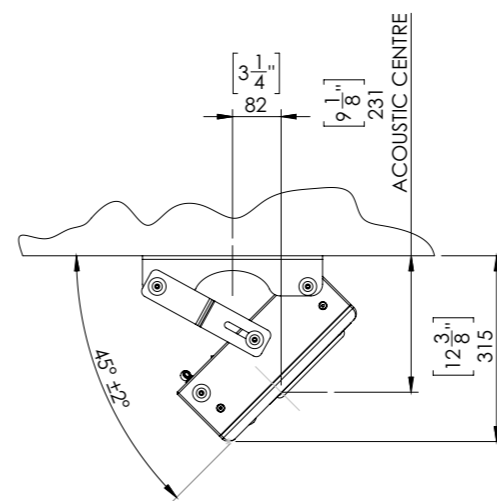
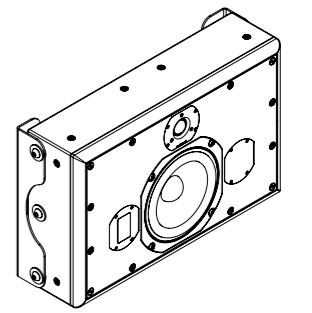
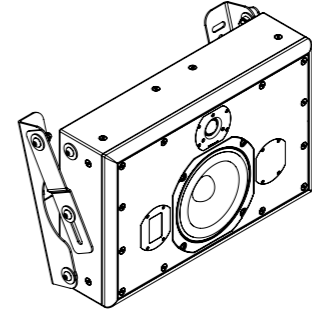
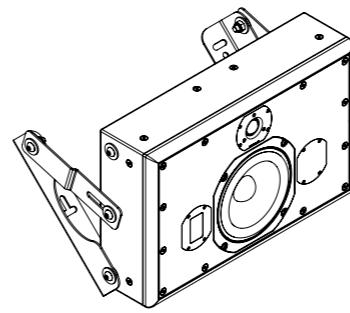

DIAGRAM 9

LANDSCAPE ORIENTATION



PORTRAIT ORIENTATION
CONFIGURATION A

PORTRAIT ORIENTATION
CONFIGURATION B

LANDSCAPE ORIENTATION

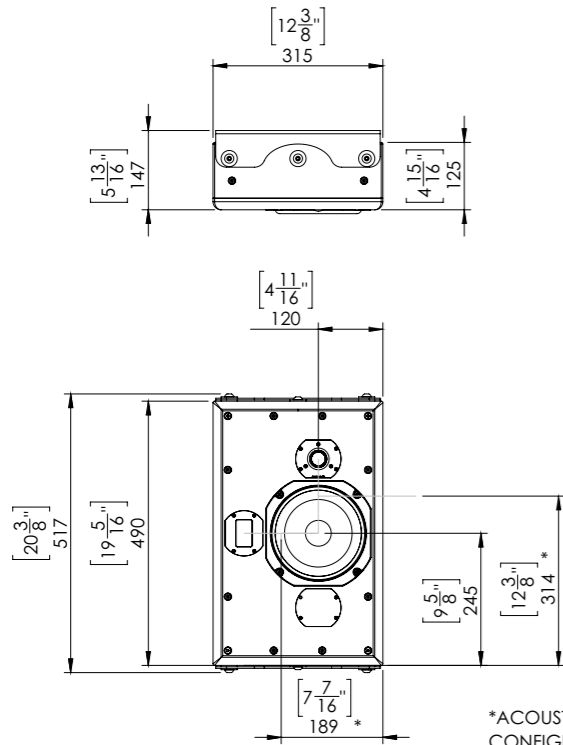
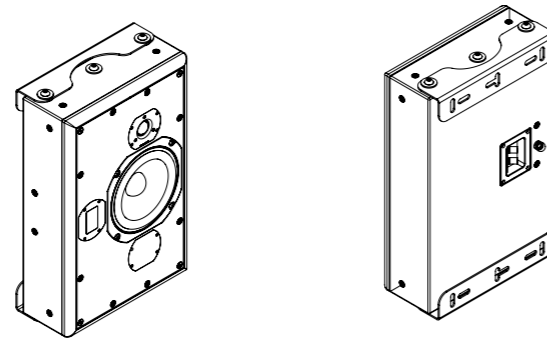
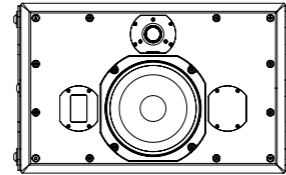
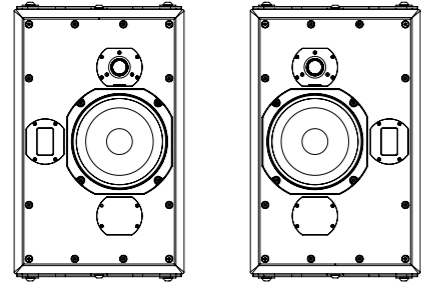

*ACOUSTIC CENTRE WILL DEPEND ON CONFIGURATION BUT IS ALWAYS AT THE CENTRE POINT BETWEEN MID/BASS DRIVER AND TWEETER

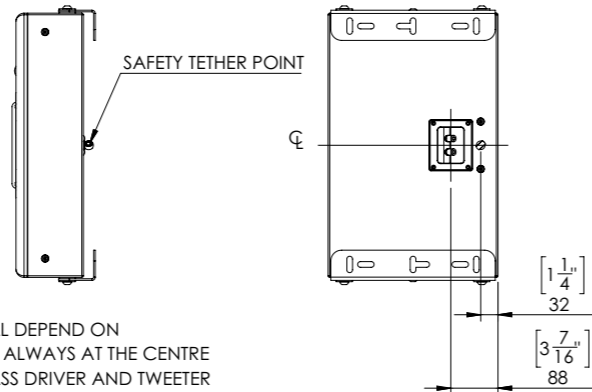

9.2 SSM25i Pro Acoustic Specifications

Drive Units Bass: 1 x SB50-1645C 8Ω
Mid: SM75-150 16Ω
HF: 1 x SH25-76S 6Ω

Low Frequency Cut-off: 47Hz (-6dB, anechoic)

High Frequency Cut-off: 25kHz (-6dB)

Crossover Frequency: 380Hz & 3.5kHz

Recommended Power Amplifier: 75W to 300W

Input Connectors: Binding Posts/4mm Plugs, single pair

MaxSPL: 110dB continuous, 116dB peak, (per pair; IEC weighted Pink Noise, 1m half-space)

Sensitivity: 85dB/W @1m

Nominal Impedance: 8Ω

Minimum Impedance: 5Ω

9.3 SSM25i Physical Specifications

Net Weight: 28.2kg / 62.2lbs.

Product Dimensions: See diagrams on following pages.

DIAGRAM 11

PORTRAIT ORIENTATION

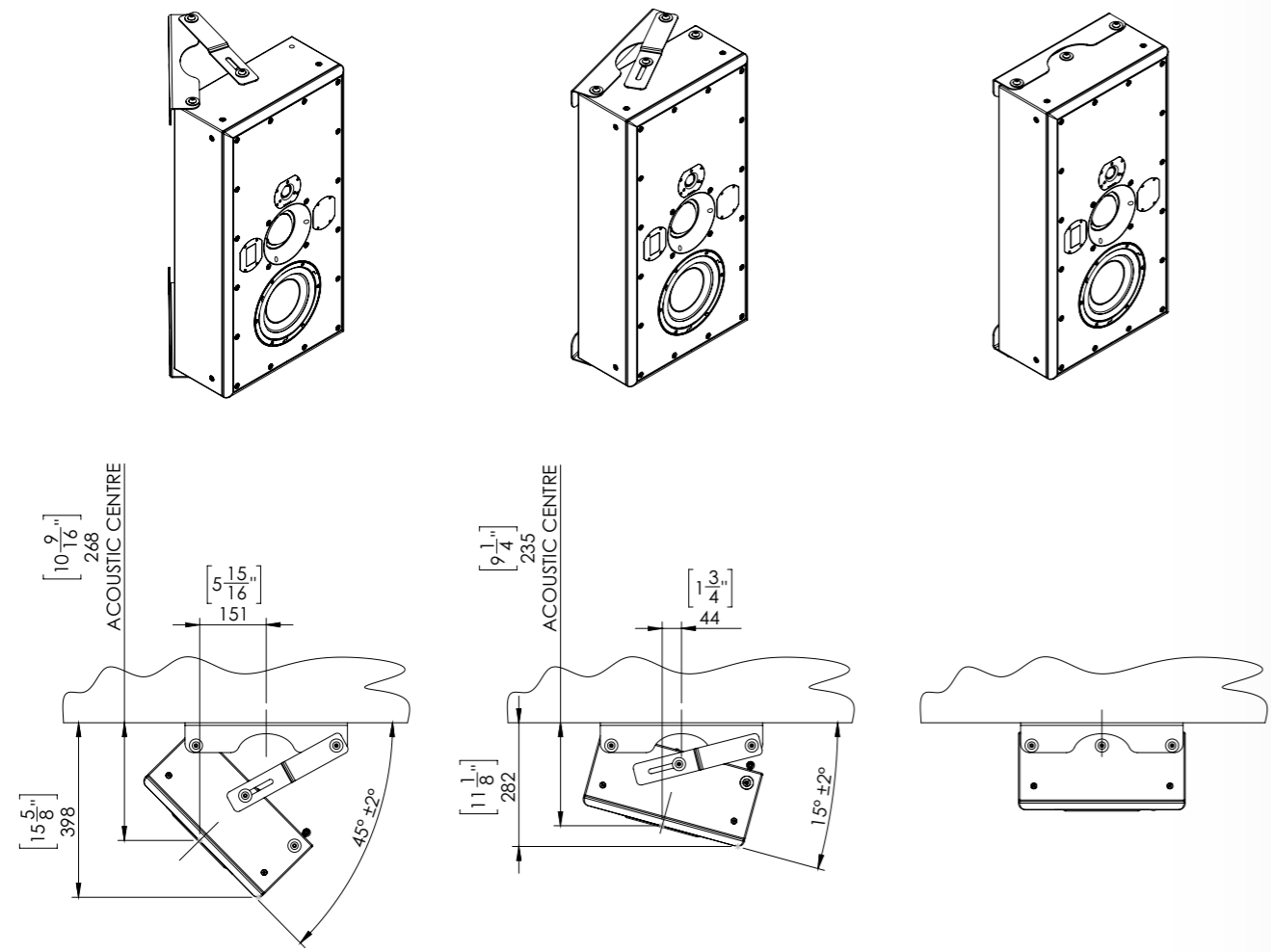
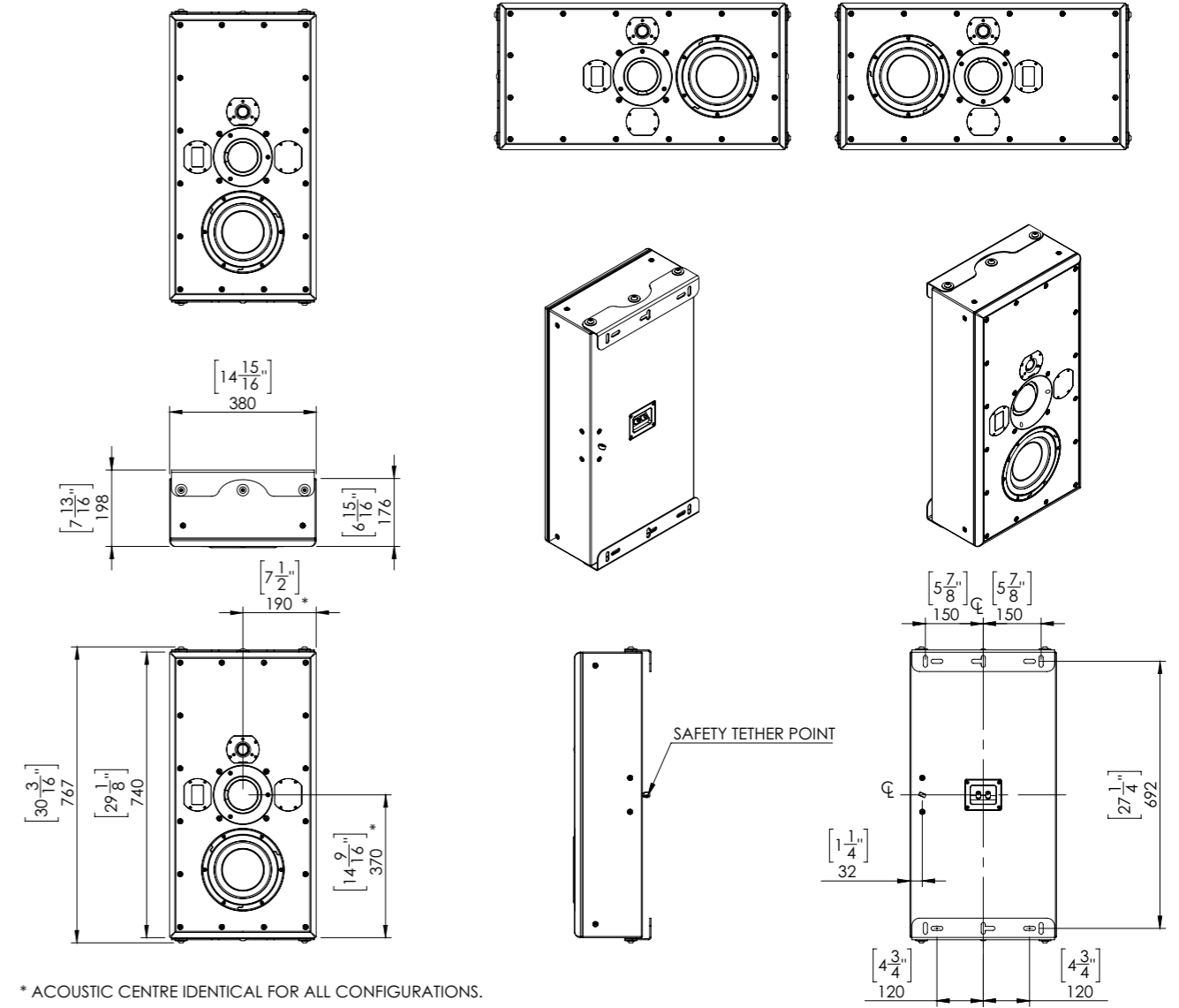

DIAGRAM 12

PORTRAIT ORIENTATION

LANDSCAPE ORIENTATION
FLAT CONFIGURATION A

LANDSCAPE ORIENTATION
FLAT CONFIGURATION B



10.1 Care & Maintenance

High technology material finishes are used in this product. The surfaces are durable and with a little care can be kept as good as new even under conditions of heavy use. Normally, a dry duster will be all that is required to keep the finishes clean. Heavy soiling can be cleaned using a cloth slightly moistened with a non-abrasive household cleaner. There are no components within the speakers that can be considered expendable, or that would benefit from regular maintenance. There is no requirement for any kind of routine service work and there is no schedule for preventative maintenance. There are no user-replaceable parts within the speaker, and in the unfortunate event of any malfunction, repair should be referred to either the supplying dealer or consultant, the relevant importer, or ATC. ATC has every confidence in the quality of each product that it manufactures.

10.2 Warranty

All ATC products are guaranteed against any defect in materials or workmanship for a period of two years from the date of purchase. Within this period, we will supply replacement parts free of charge provided that the failure was not caused by misuse, accident or negligence. Purchasers who complete the Product Registration process, either by returning a completed Warranty Card to ATC or by registering the product at www.atc.audio, will have their warranty period extended up to a period of six years from the date of purchase.

This product warranty does not provide cover for:

Damage caused by improper handling (e.g. drop/impact, water, dust/sand).

Any damage, injury or harm caused by the improper installation, fitting, mounting, suspension, connection or commissioning of ATC products by the Customer or a third party installer.

Faults resulting from normal use or wear and tear, or normal ageing of the product.

This guarantee does not limit statutory rights.

10.3 Contact

Loudspeaker Technology Ltd
Gypsy Lane, Aston Down
Stroud, Gloucestershire
GL6 8HR
United Kingdom

Telephone +44 (0)1285 760561
Email: info@atc.audio
Website: www.atc.audio

Acoustic Transducer Company is the trading name and  is the registered trade mark of Loudspeaker Technology Ltd.





Loudspeaker Technology Ltd
Gypsy Lane
Aston Down
Stroud
Gloucestershire
GL6 8HR
United Kingdom

Telephone +44 (0)1285 760561
Email: info@atc.audio
Website: www.atc.audio

Acoustic Transducer Company is the trading name.

 is the registered trade mark of Loudspeaker Technology Ltd.

**50 YEARS
IN THE
MAKING**